

NEUSPEED®

UPPER STRUT TIE BAR

GOLF IV, JETTA IV, ALL 2.0L 8V, 12V VR6, & 2.0L 8V WITH NEUSPEED SUPERCHARGER
PART# 35.10.72 & 35.10.72P

GOLF IV & JETTA IV 24V VR6
PART# 35.10.75 & 35.10.75P

INSTALLATION INSTRUCTIONS

PARTS LIST:

1 – UPPER STRUT TIE BAR	4 – ¼" X ¾" BOLTS
1 – NUTSERT TOOL	4 – LOCK WASHERS
4 – NUTSERTS	

TOOLS REQUIRED:

1 – 7/16" SOCKET	1 – 9/16" WRENCH
1 – 3/8" DRILL BIT	1 – 10mm SOCKET

1. With vehicle at rest and all four wheels on level ground, position the *NEUSPEED* Strut Tie-Bar on strut towers and center from side-to-side. Some cars have excess sealing compound on the strut towers. This **MUST** be removed around the mounting pads so the Strut Tie-Bar can sit *flat* on tower. Use a razor to cut and remove the sealing compound. Finish with touch-up paint.
2. Make sure Strut Tie-Bar mounting pads are positioned next to lip on top of strut tower (see drawing).
3. Carefully mark position of holes, center punch, drill a small pilot hole and then finish with 3/8" drill bit. Touch-up hole with paint to prevent rust. **NOTE:** Hold coolant line away when drilling passenger side strut tower.
4. Using tool supplied, install a Nutsert in each hole (see detail drawing), push down firmly as you tighten setting bolt. Torque to 10 - 12 ft/lbs. **DO NOT** allow Nutsert tool to turn during tightening or removal of setting bolt.
5. Install *NEUSPEED* Strut Tie-Bar using supplied grade-8 bolts and lock washers. **NOTE:** Torque to 10 - 12 ft/lbs.
6. Carefully double-check complete installation. Test drive carefully!

SEE REVERSE SIDE FOR DETAIL DRAWING...

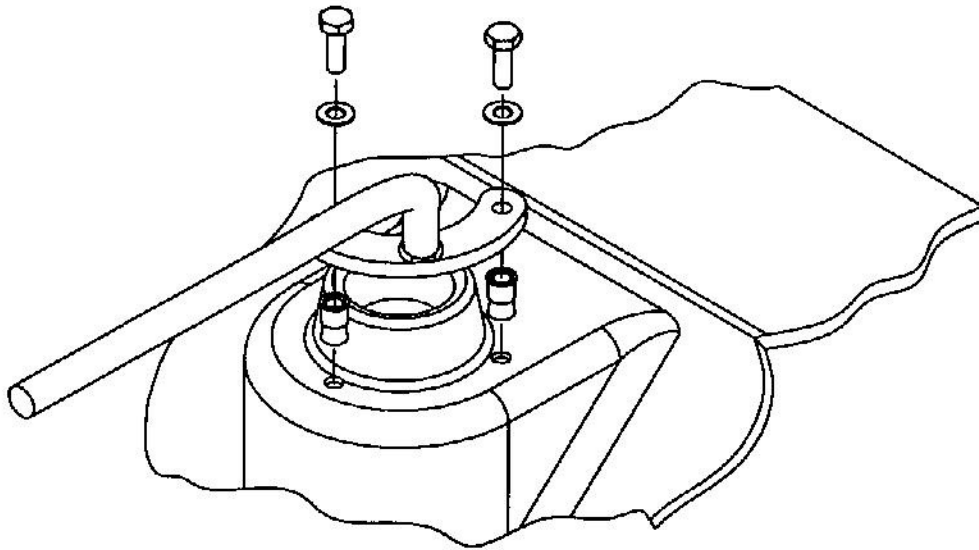
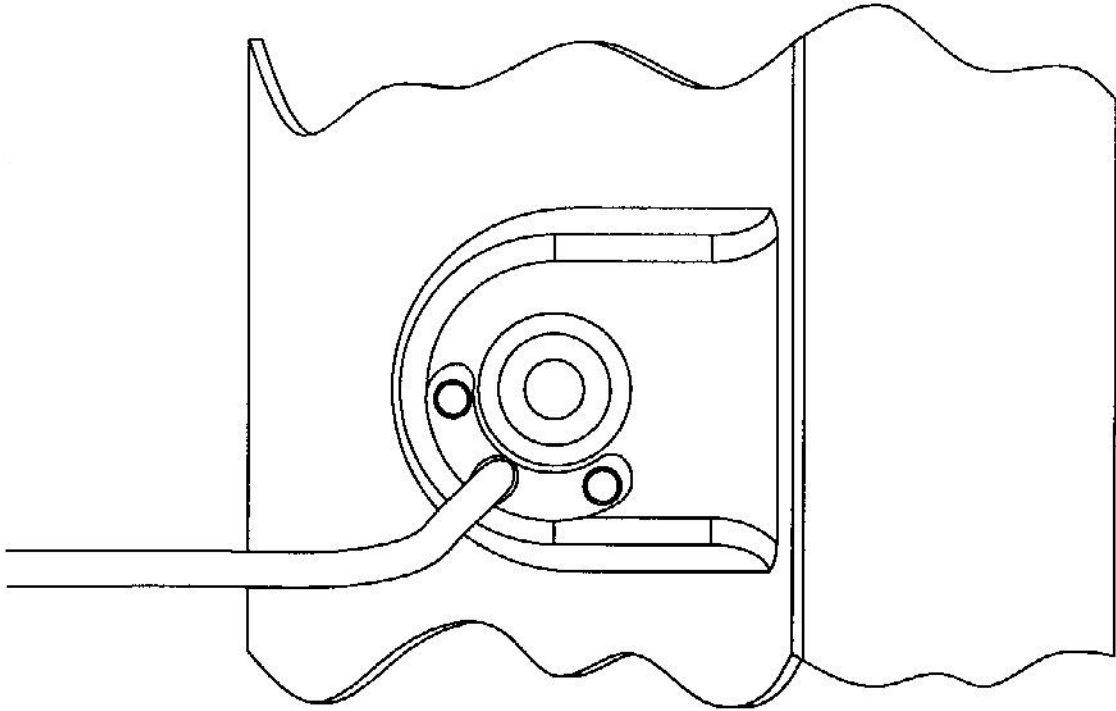

©Copyright 2003, *NEUSPEED*[®]. All rights reserved. Reproduction in whole or in part prohibited.
DOC.35.10.72 & 75(P) Rev. 11.17.03

NEUSPEED • 3300 Corte Malpaso • Camarillo, CA 93012 • 805.388.7171 • 805.388.0030 FAX
Visit us on the web...<http://www.neuspeed.com> & <http://www.apsoutlet.com>