

GENUINE ALUMINUM FOOTREST (FOR DRIVER-SIDE)

INSTALLATION AND USER'S INSTRUCTIONS

Thank you for purchasing a genuine Mazda accessory.
 Before removal and installation, be sure to thoroughly read these instructions.
 Please read the contents of this booklet in order to properly install and use the Aluminum Footrest. Your safety depends on it.
 Keep these instructions with your vehicle records for future reference.

⚠ WARNING

- There are several **⚠WARNING** and **⚠CAUTION** sections in this booklet concerning safety when installing or removing the aluminum footrest. Always read and follow them in order to prevent injuries, accidents, and possible damage to the vehicle.
 - ⚠**WARNING:** Indicates a situation in which serious injury or death could result if the warning is ignored.
 - ⚠ **CAUTION:** Indicates a situation in which bodily injury or damage to the vehicle could result if the caution is ignored.
- Do not modify the aluminum footrest.
- Do not install the aluminum footrest in any way other than described in the following instructions.
- If in any doubt, please ask your Mazda dealer to install the accessory in order to prevent errors in installation.
- If you have any questions about the use of the accessory, ask your Mazda dealer for proper advice before using it.
- Mazda and its suppliers are not responsible for injuries, accidents, and damage to persons and property that arise from the failure of the dealer or installer to follow these instructions.
- To ensure safety and reliability of the work, installation, removal and disposal work must be carried out by an Authorized Mazda Dealership.
- Be careful not to lose removed parts, and be sure that they are kept free from scratches, grease or other dirt.

**PART NAME: ALUMINUM FOOTREST
(FOR DRIVER-SIDE)**
**PART NUMBER: NE51 V8 210F
(LEFT-HAND DRIVE VEHICLE)**
VEHICLE: Mazda MX-5

受		領	
05.4.08			
M	AM	担当	
片	神	山	
マツダ		株式会社	
用品開		発グループ	

Note

To the dealer

- Please turn over these instructions to the customer after installation.

To the customer

- Keep these instructions after installation. The instructions may be necessary for installing other optional parts or removal of this accessory.
- Should the vehicle or this accessory be resold, always leave these instructions with it for the next owner.

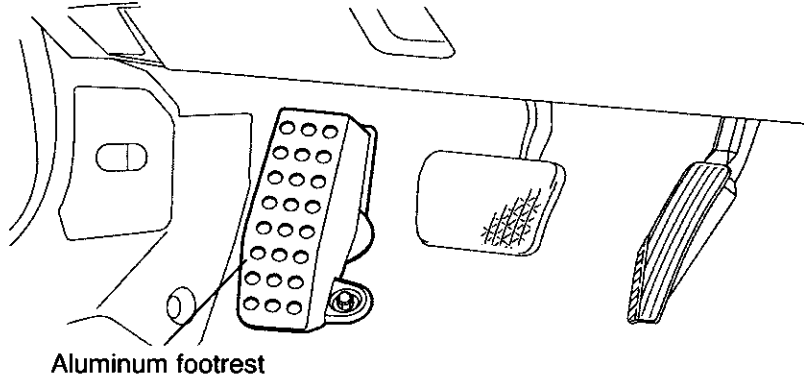

1 INSTALLATION VIEW



2 PARTS

Note

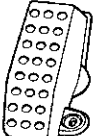
- Before installation, verify that the kit includes all the following parts and that the parts are not dirty, scratched, or damaged.

Part	Part name	Q'ty	Part	Part name	Q'ty
	Aluminum footrest (NE85 43 040)	1		Installation and User's instructions	1

3 REQUIRED TOOLS

- ★ Socket wrench
- ★ Torque wrench

4 BEFORE INSTALLATION

CAUTION

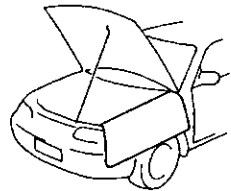
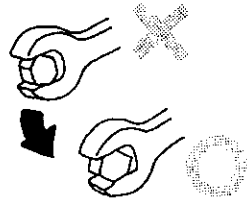
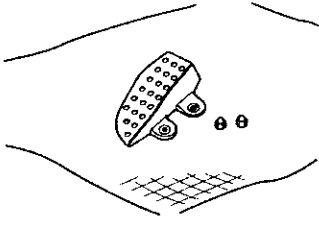
<p>Be sure to cover the vehicle body with protectors or mats to prevent stains, scratches and damage when removing/installing the vehicle parts.</p>	<p>Using improper tools may cause Damage and or broken parts. Use the correct tool for the job.</p>	<p>Place removed parts and kit parts on a protective sheet to prevent scratches.</p>
		

Note

- Refer to the Workshop Manual for removal and installation of vehicle parts. Not following the procedures for removal/installation in the Workshop Manual could result in an accident or vehicle malfunction.

5 PART REMOVAL

⚠ WARNING

- Park the vehicle on a flat, level surface, set the selector lever to P (AT vehicles) or the shift lever to 1st or R (MT vehicles), apply the parking brake and block the wheels so that the vehicle does not move during installation.

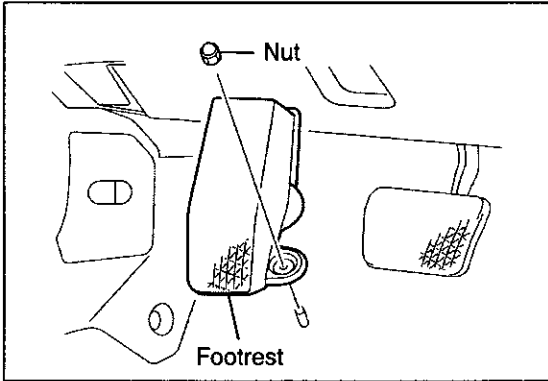

Footrest removal

1. Remove the nut and pull the footrest to remove it.

Note

- The removed nut will be reused to install the aluminum footrest.
- If there is a remaining clip on the vehicle side after removing the footrest remove, remove the clip too (clip is not reused).

5 ALUMINUM FOOTREST INSTALLATION

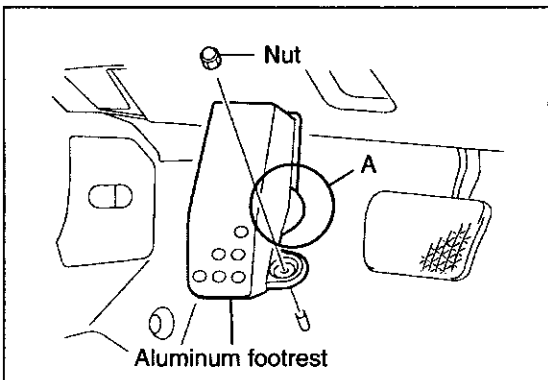

Aluminum footrest installation

1. Install the aluminum footrest in the same position as the existing footrest, firmly press section A (Refer to the figure on the left) to temporarily install it in place.
2. Secure the aluminum footrest using the existing nut.

Tightening Torque

Nut: 2.45–3.53 N·m

{25.0–35.9 kgf·cm, 21.7–31.2 in·lbf}

⚠ CAUTION

- Tighten the nut securely
Be careful when tightening the nut. If the nut are tightened to other than the specified torque, the aluminum footrest could become damaged or fall off.

— TO THE CUSTOMER —

Note

- Tighten the nut securely
- Be careful when tightening the nut. If the nut are tightened to other than the specified torque, the aluminum footrest could become damaged or fall off.
 - (1) When washing the vehicle, do not use a scrubber so that scratching of the surface is prevented.
 - (2) If dirt is difficult to remove by washing with water, use a diluted, mild detergent, and then wash with water.

INSTALLATION INSPECTION SHEET

MX-5

**ALUMINUM FOOTREST
(FOR DRIVER-SIDE)**

**NE51 V8 210F
(LEFT-HAND DRIVE VEHICLE)**

Inspection items after installation

- Inspect the installed/reinstalled parts for the following items.

Part	Check item (○)		
	Clearance/Fit	Scratches/Dirt	Installation/Tightening/ Engagement
Aluminum footrest	○	○	○

Installation inspection sheet for Aluminum Footrest

Date _____, _____, _____				
VIN. _____				
Approved		Checked		Person in charge

The term of validity for this sheet: 3 months