



Important!

Please give copies to all
your VW Technicians

Technical Bulletin

Subject: **Transfer Case, Checking/Replacement (BN)**

Group: **34**

Number: **04-02**

Model(s): **Touareg 3.2L V6 (eng. code AZZ, BAA) 2004**
Touareg 4.2L V8 (eng. code AXQ, BHX)

Date: **June 21, 2004**

Instructions: Perform this procedure on all applicable vehicles within the Limited New Vehicle Warranty

ATTENTION!

This Technical Bulletin is in effect for 15 months from date of publication as listed above. After that date, this Technical Bulletin will expire and no longer be in effect.

Condition

Transfer case may require replacement depending on production batch number (see Page 2).

Production

For vehicles from 4D014234 to 4D038730 with transfer case batch number 2.2

Service

Requirements:

Vehicle must meet ALL of the following criteria.

- 1 - Procedure is valid only for vehicles that show the BN code in the OTIS View Campaign inquiry screen on the day of repair.
- 2 - Vehicle must be within the Limited New Vehicle Warranty.
- 3 - Procedure must be performed within the allotted time frame stated in this Technical Bulletin.

Note:

Procedure must also be performed on applicable vehicles in Dealer inventory.



Important!

Please give copies to all your VW Technicians

Technical Bulletin

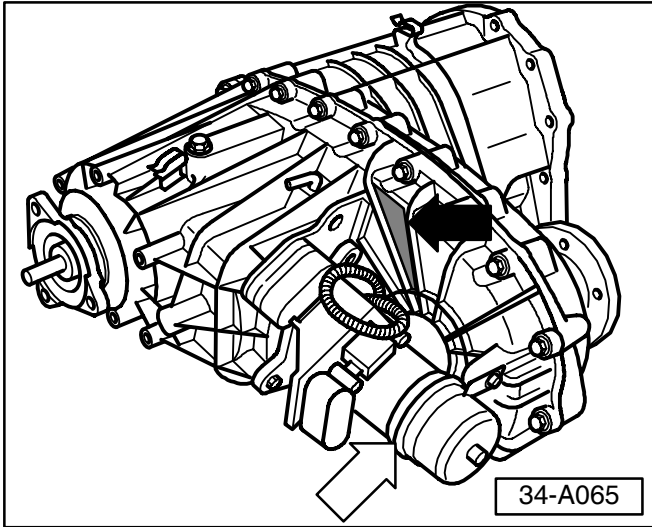

Procedure:

With vehicle properly raised on lift.

- ◀ – Check for transfer case production batch number (location at arrow) using the following (see below).



- ◀ – Using an inspection mirror and an additional light source locate the batch number (white arrow) by looking over the top of the Differential motor (white arrow in illustration 34-A065).

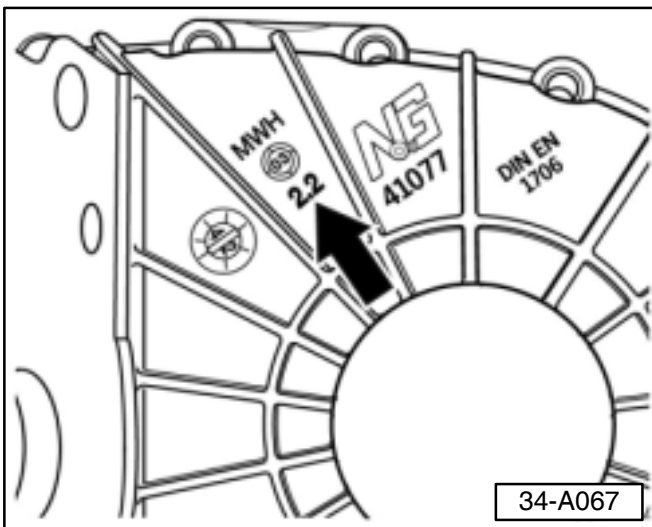

- ◀ Transfer case production batch number (arrow).

If production batch number is NOT 2.2:

- No further work is required.

If production batch number is 2.2:

- Replace transfer case (see Repair Manual Group 34 - Manual Transmission *Controls, Housing*, “Transfer case, removing and installing”).



Important!

Please give copies to all
your VW Technicians

Technical Bulletin

Parts required:

Engine	Part Number	Description	QTY	Location
3.2 L V6 (eng. code AZZ, BAA) 4.2 L V8 (eng. code AXQ, BHX)	N 909 417 01	Socket head bolt	18	Front Driveshaft to transfer case flange & Rear Driveshaft to rear differential flange
	N 100 289 08	Hexagon nut	3	Rear Driveshaft to transfer case flange
	N 909 913 01	Hexagon bolt	4	Crossmember to body
	N 105 167 01	Hexagon collar screw	2	Crossmember to transfer case
3.2 L V6 (eng. code AZZ, BAA)	100 341 012 X	Transfer case	1	Transmission
4.2 L V8 (eng. code AXQ, BHX)	100 341 010 SX	Transfer case	1	

Note:

10 Bolts securing transfer case to transmission do not need to be replaced as described in Repair Manual information.

CAUTION!

Part numbers listed in this bulletin are for reference only. Always check with your Parts Dept. for the latest parts information.



Important!

Please give copies to all your VW Technicians

Technical Bulletin

Required Vehicle Update Technical Bulletin Time Requirements/ Reimbursement

To ensure prompt and proper payment, be sure to enter, immediately upon completion of the repair work, the applicable reimbursement code listed below. Claims will only be paid for vehicles that show the BN code in the OTIS View Campaign inquiry screen on the day of repair.

BN Data Entry Procedure Use Claim Type RC

Repair Code (Damage Code Field)	Time Units	Work Scope
BN 11	20 T.U.	Check Transfer case Batch Number only
BN 12	250 T.U.	Replace Transfer Case for 3.2L V6 (includes check batch number)
BN 13	250 T.U.	Replace Transfer Case for 4.2L V8 (includes check batch number)

There is NO Reimbursement for Vehicle Wash or Loaner Vehicle

The system automatically enters parts and labor applicable to the above listed code.

For vehicles that, according to your information, cannot be corrected or reached, and one of the codes below best describe the reason, please enter one of the applicable codes into the system:

- BN20 Customer Refused Repairs
- BN30 Total Loss
- BN40 Vehicle Stolen
- BN50 Vehicle Exported

Additional Required Vehicle Update Technical Bulletins

Some of the affected vehicles may be involved in additional Required Vehicle Update Technical Bulletins. Please check your OTIS View Campaign inquiry screen so that any additional required work can be done simultaneously.

Required Vehicle Update Technical Bulletin Verification

For verification, always check the OTIS View Campaign inquiry screen. The OTIS system is the only binding inquiry and verification system; other systems are not valid and may result in non-payment of a claim.

Help for Claim Input

For questions regarding claim input, contact your appropriate Warranty Claim specialist.

Please do not contact the Campaign Helpline regarding claim input.

Required Customer Notification

Inform your customer in writing by recording on the Repair Order any and all work that was conducted on the vehicle, including any and all updates completed under this Technical Bulletin.