



Service Action Circular

Code: **VQ**

September 2004

Subject: 2004 Model Year Volkswagen Touareg Vehicles Modify Rubber Around Power Steering Fluid Line and Transmission Fluid Line Located Behind Radiator Grille

This is to inform you of the initiation of a service action involving some 2004 model year Volkswagen Touareg vehicles.

Problem Description Volkswagen has found that a rubber part can rub against the power steering and/or transmission fluid lines located behind the radiator grille. In rare cases, this rubbing can lead to corrosion of the lines and possibly even a fluid leak.

Remedial Action Modify the rubber part around the power steering and transmission fluid lines.

Vehicle Identification Number Range The vehicles affected by this action are within the following vehicle identification number range:

WVG__7L_4D000001 - WVG__7L_4D068300

Please note that the above VINs represent the lowest and highest serial numbers of affected vehicles. Use of the OTIS campaign inquiry system will allow you to determine whether or not a particular vehicle, within the above VIN range, requires the corrective work.

Note: It is recommended that a screen print of the OTIS View Campaign inquiry screen be attached to the repair order. Volkswagen will not reimburse under this action any duplicate repair work or a repair outside the VIN range.

Owner Notification Mailing Volkswagen will notify all known owners of affected vehicles directly by first-class mail on or about September 3, 2004. A sample copy of the owner letter is enclosed for your information.

Vehicle Allocation A computer list containing the VINs including the owner names and addresses of vehicles that, according to our records, are located within your area of responsibility (AOR) and require this action to be performed will be provided under separate cover.

Parts Information There are no parts required for this action.

Time Requirements/ Reimbursement

To ensure prompt and proper payment, be sure to enter, immediately upon completion of the repair work, the reimbursement code listed below. Claims will only be paid for vehicles that show the **VQ** code in the OTIS View Campaign inquiry screen on the day of repair. It is therefore recommended that a screen print of the OTIS View Campaign inquiry screen be attached to the repair order.

VQ Data Entry Procedure

Repair Code (Damage Code Field)	Time Units	Work Scope
VQ 12	40 T.U.	- Modify rubber around power steering line and transmission fluid line
<i>There is <u>NO</u> reimbursement for Vehicle Wash or Loaner Vehicle.</i>		

The system automatically enters labor applicable to the above listed code.

For vehicles that, according to your information, cannot be corrected or reached, and one of the codes below best describe the reason, please enter one of the applicable codes into the system:

- **VQ 20 Customer Refused Repairs**
- **VQ 30 Total Loss**
- **VQ 40 Vehicle Stolen**
- **VQ 50 Vehicle Exported**

Additional Campaigns

Some of the affected vehicles may be involved in an additional corrective action. Please check your OTIS View Campaign inquiry screen so that any additional required work can be done simultaneously.

Campaign Verification

For verification, **always** check the OTIS View Campaign inquiry screen. The OTIS system is the **only** binding campaign inquiry and verification source; other sources are not valid and may result in non-payment of a claim.

Service Help

If you have a question regarding this or any other campaign, please call (800) 741-2919.

Dealer Personnel Information

Please inform and/or provide a copy of this communication to every person in your dealership who has campaign-related responsibilities, including parts and accounting personnel.

Thank you for your cooperation.

Sincerely,



Maria Cotter
Volkswagen Service & Quality

Volkswagen of America, Inc.



3800 Hamlin Road
Auburn Hills, MI 48326

September 2004

**Subject: Service Action VQ
2004 Model Year Volkswagen Touareg Vehicles
Modify Rubber Around Power Steering Fluid Line
and Transmission Fluid Line Located Behind Radiator Grille**

Dear Volkswagen Owner:

We are writing to inform you of a service action on some 2004 model year Volkswagen Touareg vehicles. Our records show that you are the owner of one of these vehicles.

What Is The Problem?

Volkswagen has found that, on affected vehicles, a rubber part can rub against the power steering and/or transmission fluid lines located behind the radiator grille. In rare cases, this rubbing can lead to corrosion of the lines and possibly even a fluid leak.

What Will Volkswagen Do?

In order to correct this condition on your vehicle, we will modify the rubber part around the power steering and transmission fluid lines.

What We Would Like You To Do

Please contact your authorized Volkswagen dealer and arrange for an appointment to have this work performed without delay. This work will typically take about one-half hour, depending on your dealer's workshop schedule. Your dealer may need additional time for the preparation of the repair as well as to accommodate the daily workshop schedule. Of course, this service will be performed free of charge.

Please retain this letter in the vehicle glove compartment with the vehicle Owner's Manual.

Lease Vehicles

If you are the lessor and registered owner of the vehicle identified in this action, please forward this information immediately via first-class mail to the lessee within ten (10) days of receipt of this notification.

Have You Changed Your Address Or Sold The Vehicle?

If you have, please fill out the enclosed prepaid Owner Reply card and mail it to us so we can update our records.

Service Help from Us

If your authorized Volkswagen dealer fails or is unable to complete this work free of charge within a reasonable time, please call or write to:

*Volkswagen of America, Inc.
Attn: Customer CARE Center (VQ)
3499 West Hamlin Road
Rochester Hills, MI 48309
1-800-893-5298*

We regret any inconvenience this matter may cause. Thank you for driving a Volkswagen!

Sincerely,

Maria Cotter
Volkswagen Service & Quality

Work Sequence:

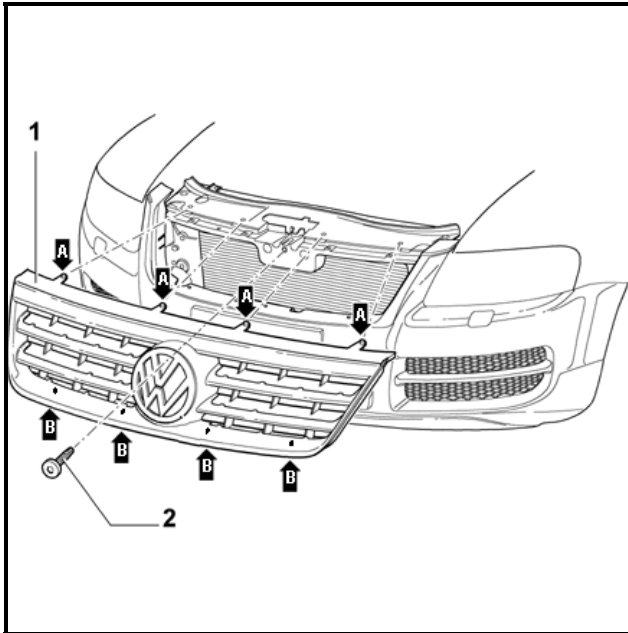

- Open hood

⇐ Remove screw -2-

Note: Screw -2- is accessed by going through upper hole in the emblem

⇐ Push down tabs -arrow A- using openings in the radiator support cover

⇐ Lift up tabs -arrow B- on the bottom of the grille and remove grille -1- from the vehicle

Note: Tabs -B- can be accessed through lower opening of the grille

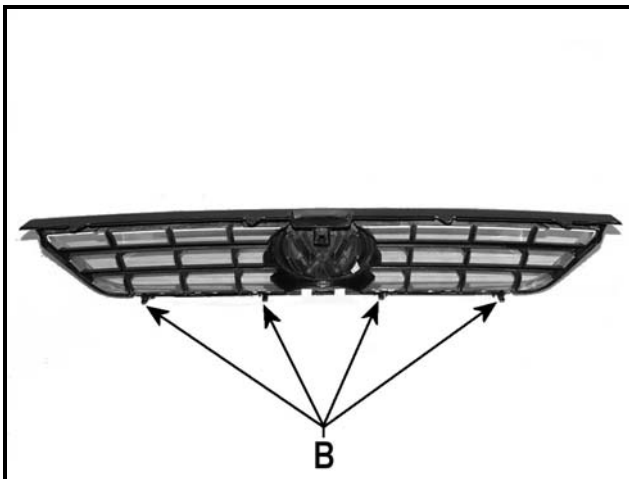

⇐ Illustration shows back side of grille and location of lower tabs -B-

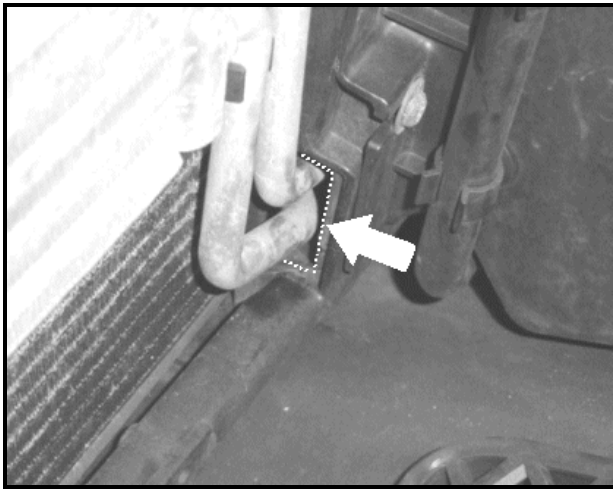

⇐ At left bottom corner of radiator, use a small knife and carefully cut away the rubber contacting the power steering fluid lines

IMPORTANT! Only cut away rubber contacting the fluid lines from the area inside dotted lines -arrow-

CAUTION: DO NOT DAMAGE RADIATOR OR FLUID LINE WHEN REMOVING RUBBER

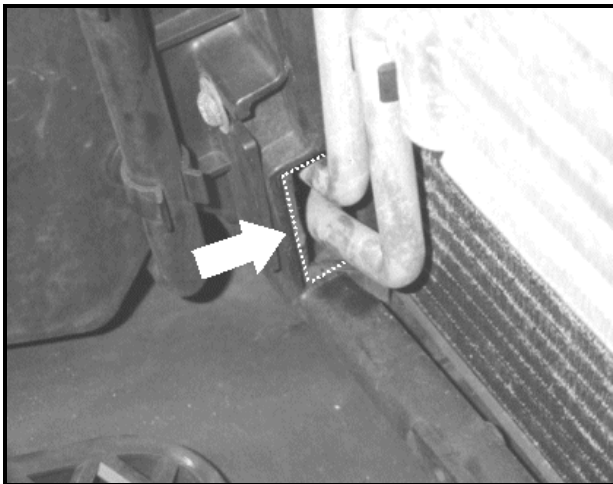

⇐ At right bottom corner of radiator, use a small knife and carefully cut away the rubber contacting the automatic transmission fluid lines

IMPORTANT! Only cut away rubber contacting the fluid lines from the area inside dotted lines -arrow-

CAUTION: DO NOT DAMAGE RADIATOR OR FLUID LINE WHEN REMOVING RUBBER

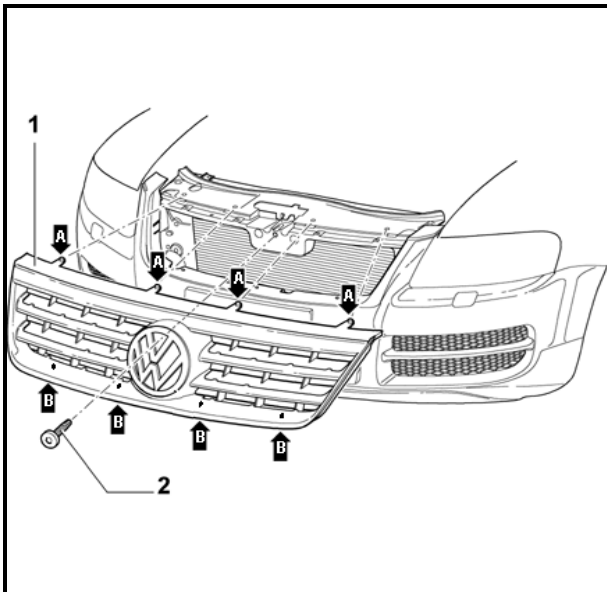

⇐ Reinstall radiator grille -1- by sliding into position until tabs along the top -arrow A- and tabs along the bottom -arrow B- snap into position

⇐ Secure radiator grille with screw -2- and tighten to 1.5 Nm (13 in. lbs.)

- Close hood and properly dispose of removed parts