

**Important! Please Provide A Copy To All Personnel With Campaign-Related Responsibilities!**  
**THIS REPLACES THE UY CIRCULAR DATED APRIL 2005**



# Compliance Recall Circular

**REVISED**

**Code: UY**

May 11, 2005

**Subject: 2004-2005 Model Year Touareg Vehicles  
Inspect Rear Outboard Seat Belts and, If Necessary,  
Install Seat Belt Shortening Clips**

This is to inform you of a compliance recall involving some 2004-2005 model year Touareg vehicles.

**Problem Description** Volkswagen has found that some 2004-2005 model year Touareg vehicles may not fully comply with a part of Federal Motor Vehicle Safety Standard (FMVSS) 208 regarding the use of the seat belt locking feature.

This locking feature is used when installing a child seat in the rear outboard seating positions. A small number of child seats cannot be installed as required by FMVSS 208 because they have a very short belt routing path.

This condition does not affect adult use of the seat belts, nor does it affect the center rear seat belt.

**Remedial Action** Inspect both rear outboard seat belts and, if necessary, install seat belt shortening clips at the rear outboard seating positions.

Additionally, an owner's manual insert entitled "Child Restraint Installation in Your Vehicle" must be inserted in the owner's manual of each affected vehicle in the section before Booklet 2.1, "Safety First."

**Vehicle Identification Number Range** The vehicles affected by this action are within the following vehicle identification number range:

WVG\_\_ \_7L\_4D000056 - WVG\_\_ \_7L\_5D030829

*Please note that the above VINs represent the lowest and highest serial numbers of affected vehicles. Use of the OTIS campaign inquiry system will allow you to determine whether or not a particular vehicle, within the above VIN range, requires the corrective work.*

*Note: It is recommended that a screen print of the OTIS View Campaign inquiry screen be attached to the repair order. Volkswagen will not reimburse under this action any duplicate repair work or a repair outside the VIN range.*

**Limitation of Sale or Lease of Certain Vehicles** Federal law prohibits any person from knowingly selling, or offering for sale, any motor vehicle that does not comply with applicable motor vehicle safety standards prescribed under Chapter 301 ("Motor Vehicle Safety") of Title 49, United States Code. **It is therefore imperative that any vehicle in your inventory that is affected by this recall is corrected prior to delivery for sale or lease.**

**Owner Notification Mailing**

Volkswagen notified all known owners of affected vehicles directly by first-class mail on or about April 11, 2005. Each notification letter included an owner’s manual insert entitled “Child Restraint Installation in Your Vehicle”. They were instructed to place the insert in their owner’s manual in the section before Booklet 2.1, “Safety First.” A sample copy of the owner notification letter is enclosed for your information.

**Parts Information**

You received an initial allocation of parts. During the campaign launch period, parts will be blocked and released by VIN through Special Services. Refer to the VWHub for campaign parts updates. After the launch period, the block may be lifted and then parts can be ordered through your facing parts depot. For your in-stock vehicles, you can order copies of the owner’s manual insert entitled “Child Restraint Installation in Your Vehicle” from Resolve by calling 800-544-8021.

**Time Requirements/ Reimbursement**

To ensure prompt and proper payment, be sure to enter, immediately upon completion of the repair work, the applicable reimbursement code listed below. Claims will only be paid for vehicles that show the **UY** code in the OTIS View Campaign inquiry screen on the day of repair. It is therefore recommended that a screen print of the OTIS View Campaign inquiry screen be attached to the repair order.

**UY Data Entry Procedure**

**NEW** 

Repair Code (Damage Code Field)	Time Units	Work Scope
<b>UY 11</b>	<b>10 T.U.</b>	- Check both rear outboard seat belts; No further work required
<b>UY 15</b>	<b>20 T.U.</b>	- Inspect both rear outboard seat belts; Install clip on left & right rear outboard seat belts 2 7L0 857 837 Bracket with locking clamp
<b>UY 1L</b>	<b>160 T.U.</b>	- Check both rear outboard seat belts; Replace <u>left</u> rear outboard seat belt 1 7L0 857 805A *** Rear seat belt -Left
<b>UY 1R</b>	<b>160 T.U.</b>	- Inspect both rear outboard seat belts. Replace <u>right</u> rear outboard seat belt 1 7L0 857 806A *** Rear seat belt -Right

***There is NO reimbursement for Vehicle Wash or Loaner Vehicle.***

The system automatically enters labor and parts applicable to the above listed codes.

For vehicles that, according to your information, cannot be corrected or reached, and one of the codes below best describe the reason, please enter one of the applicable codes into the system:

- **UY 20 Customer Refused Repairs**
- **UY 30 Total Loss**
- **UY 40 Vehicle Stolen**
- **UY 50 Vehicle Exported**

**UYAB Customer  
Satisfaction Seat Belt  
Replacement  
Authorization**  
**NEW** 

We will consider requests for replacement of **both** rear outboard seat belts under this action as a UYAB claim, if, after the seat belt clips are installed, the customer returns because he/she is experiencing the ALR feature activating too soon when an adult is using the rear seat belts, or if the customer expresses other dissatisfaction. **You must contact the Campaign Helpline at (800) 741-2919 to obtain a special authorization code prior to performing the belt replacements or your claim will be denied. ONLY a Campaign Helpline person can provide you with this authorization code.**

**UYAB Expiration**  
**May 31, 2006** 

This UYAB customer satisfaction seat belt replacement procedure is effective through May 31, 2006, after which time it will expire and will no longer be performed.

**Additional Campaigns**

Some of the affected vehicles may be involved in an additional corrective action. Please check your OTIS View Campaign inquiry screen so that any additional required work can be done simultaneously. Ensure customer approval is obtained before proceeding with any additional work.

**Campaign Verification**

For verification, **always** check the OTIS View Campaign inquiry screen. The OTIS system is the **only** binding campaign inquiry and verification source; other sources are not valid and may result in non-payment of a claim.

**Service Help**

If you have a question regarding this or any other campaign, please call (800) 741-2919.

**Dealer Personnel  
Information**

Please inform and/or provide a copy of this communication to every person in your dealership who has campaign-related responsibilities, including parts and accounting personnel.

Thank you for your cooperation.

Sincerely,

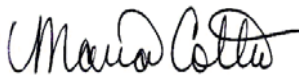

Maria Cotter  
Product Compliance

## Volkswagen of America, Inc.



3800 Hamlin Road  
Auburn Hills, MI 48326

April 2005

**Subject: Compliance Recall UY  
2004-2005 Model Year Touareg Vehicles – CHILD SEAT INSTALLATION  
Inspect Rear Outboard Seat Belts and, if Necessary, Install Seat Belt Shortening Clips**

Dear Volkswagen Owner:

This notice is sent to you in accordance with the requirements of the National Traffic and Motor Vehicle Safety Act.

Volkswagen has determined that some 2004 - 2005 model year Touareg vehicles fail to conform to the requirements of Federal Motor Vehicle Safety Standard (FMVSS) 208, "Occupant Crash Protection," regarding the use of the seat belt locking feature. This locking feature is used when installing a child seat in the rear outboard seating positions. Our records show that you are the owner of one of these vehicles.

### **What Is The Problem?**

Certain child seats that have a very short belt routing path cannot be installed as required by FMVSS 208.

If you have a child seat that was built with the LATCH system, you can use the LATCH system in the vehicle to properly secure the child seat. Again, be sure to always follow the instructions that came with the child seat.

This condition does not affect adult use of any seat belt, nor does it affect child seat installation in the center rear seat location.

Except for the driver's position, all Touareg seat belts are equipped with retractors that convert from an emergency locking retractor (ELR) to an automatic locking retractor (ALR). This locking feature is used when installing a child seat. The belts convert to the ALR mode after the webbing has been pulled all the way out of the retractor. As the belt is then released into the retractor, the system remains in the ALR mode so that the belt can be tightened to secure a child restraint.

However, when installing a child restraint with a very short belt path in either of the rear outboard seating positions, the retractor may return to the ELR mode before all of the belt webbing has been fed back into the retractor. If this happens, a child restraint with a short belt path will not be properly secured as determined by the FMVSS requirement. Failure to properly restrain the child seat safely could result in injury to the child in a crash.

### **What Will Volkswagen Do?**

In order to identify and correct this condition, we will inspect the rear outboard seat belts on your vehicle and, if necessary, install special clips.

Additionally, enclosed with this letter is an owner manual supplement entitled "Child Restraint Installation in Your Vehicle." Please read this insert carefully and file it in your owner's manual before booklet 2.1, "Safety First."

### **What We Would Like You To Do**

If you do not have, or do not expect to have, a child seat installed in the rear outboard seating positions, please contact your authorized Volkswagen dealer and arrange for an appointment in May, 2005 so that this recall work can be performed on your vehicle at that time.

If you now have, or expect to have, a child seat installed in either of the two rear outboard seating positions, please contact your authorized Volkswagen dealer without delay to arrange for an appointment so that this recall work can be performed before installation of the child seat.

This service should take less than one half hour; however, your dealer may need additional time for the preparation of the repair as well as to accommodate the daily workshop schedule. This work will, of course, be free of charge.

### **About the Seat Belts in Your Vehicle**

Since this noncompliance will affect only a small number of child restraints, we would like you to know that adults can use the rear seat belts normally.

Most child seats can be secured in your vehicle in accordance with FMVSS 208 requirements. This includes rear-facing infant seats, most forward-facing child seats, and booster seats. Only a few child seats will use so little seat belt length to cause the retractor to switch from ALR to ELR mode.

When using a child seat in your vehicle, be sure to always follow the instructions that came with the child seat, and be sure to always put the seat belt height adjuster in the top-most position. Since the center rear seat belt is not affected by this noncompliance, this seating position is an option for securing the small number of child seats that cannot be installed in the rear outboard positions as per FMVSS 208.

If you have a child seat that was built with the LATCH system, you can use the LATCH system in the vehicle to properly secure the child seat. Again, be sure to always follow the instructions that came with the child seat.

### **Lease Vehicles**

If you are the lessor and registered owner of the vehicle identified in this action, the law requires you to forward this information immediately via first-class mail to the lessee within ten (10) days of receipt of this notification.

### **Have You Changed Your Address Or Sold The Vehicle?**

If you have, please fill out the enclosed prepaid Owner Reply card and mail it to us so we can update our records.

### **Reimbursement of Expenses**

If you have previously paid for replacement of the rear outboard seat belts because they would not secure a child restraint, the enclosed form explains how to request reimbursement. We would be pleased to review your reimbursement request.

### **Service Help from Us**

If your authorized Volkswagen dealer fails or is unable to complete this work free of charge within a reasonable time, please call or write to:

*Volkswagen of America, Inc.*  
**Attn: Customer CARE Center – Hills East (UY)**  
3499 West Hamlin Road  
Rochester Hills, MI 48309  
1-800-893-5298

If you still cannot obtain satisfaction, you may file a complaint with: Administrator, National Highway Traffic Safety Administration, U.S. Department of Transportation, 400 Seventh Street, SW, Washington, DC 20590. Telephone: (888) 327-4236.

We regret any inconvenience this matter may cause. Thank you for driving a Volkswagen!

Sincerely,

Maria Cotter  
Product Compliance

**Parts:**

<u>Quantity</u>	<u>Part Number and Date</u>	<u>Part Name</u>
2	7L0 857 837	Bracket with locking clamp (Set)
1	7L0 857 805 A *** dated 07.08.2004 or later	Rear Seat Belt Left
1	7L0 857 806 A *** dated 07.08.2004 or later	Rear Seat Belt Right
	Shop Supplies	Loctite® threadlocker blue 242

( \*\*\* Color code per ETKA)



- ⇐ 7L0 857 805A/806A – Seat belt -1-
- ⇐ 7L0 857 837 - Bracket -3- with locking clamp -2-

**Special Tools:**

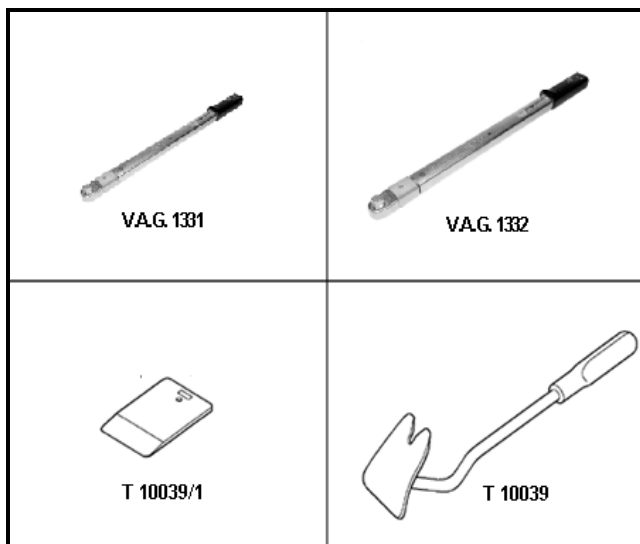

- ⇐ Torque wrench V.A.G. 1331 or equivalent
- ⇐ Torque wrench V.A.G. 1332 or equivalent
- ⇐ Wedge T 10039/1 or equivalent
- ⇐ Wedge T 10039 or equivalent

## Work Sequence:



### Section A – Check Rear Seat Belt Identification Label

- Open both rear doors
- ⇐ Illustration is showing left rear seat belt
- ⇐ Check the date -arrow- on the left and right outer rear seat belt labels;

Note: The date is shown in day, month year (dd.mm.yyyy) format

- If the date is 07.08.2004 (**7 August 2004**) or later on the left **and** right seat belt label, no further work is required
- If the date is earlier than 07.08.2004 on only one of the seat belt labels, proceed to **Section B**

Note: Only one seat belt is allowed to be replaced if the label is dated earlier than 7 August 2004

- If the date is earlier than 07.08.2004 on **both** left and right seat belt labels, proceed to **Section D**

### Section B – Rear Seat Belt Removal

 **WARNING**  
Observe safety precautions for belt tensioners

- Disconnect batteries

 **WARNING**  
Prior to handling or servicing batteries, read, understand and observe the Warning and Safety measures for lead-acid batteries

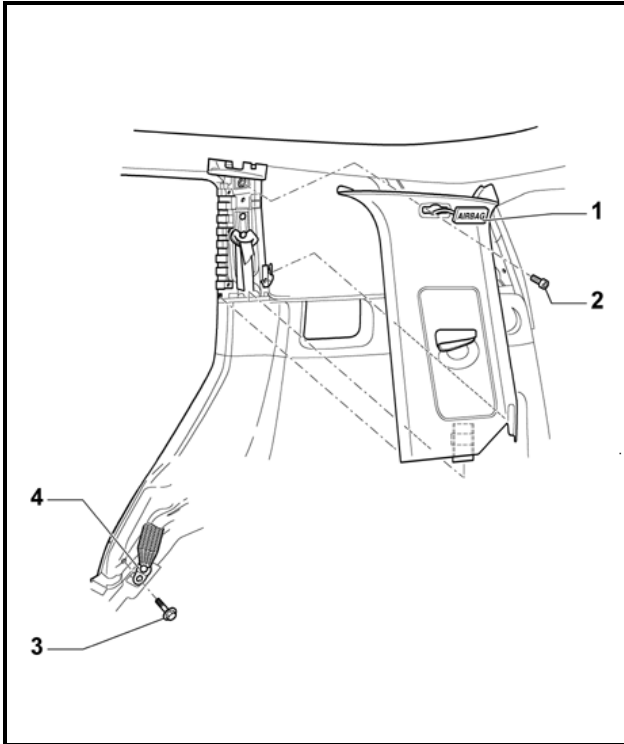

- ⇐ Remove air bag emblem -1- and remove screw -2-
- ⇐ Fold seat cushion forward and remove bolt -3- (50 Nm)
- ⇐ Remove belt anchor -4- from body
- Pull C-pillar trim out of mountings in body and door seal molding
- Remove trim and pull seat belt through opening

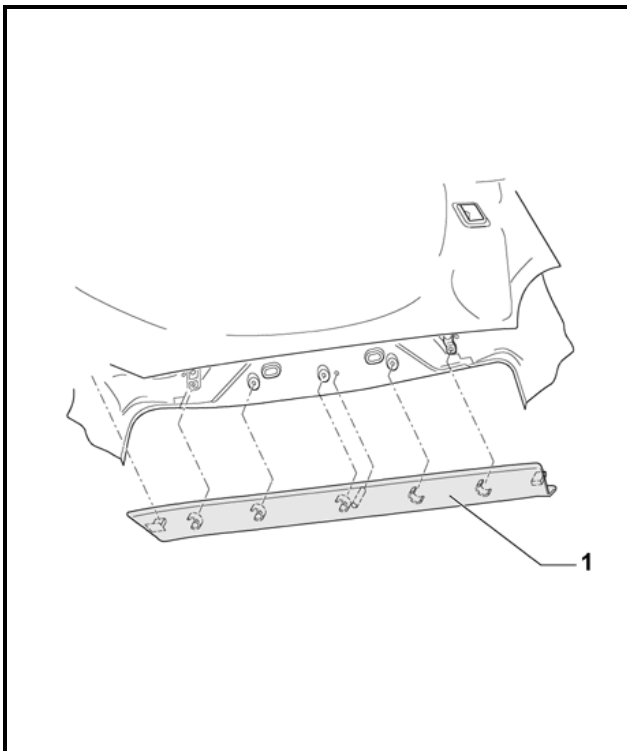

- Open tailgate
- ⇐ Pull roof end strip -1- downward out of mounting in roof



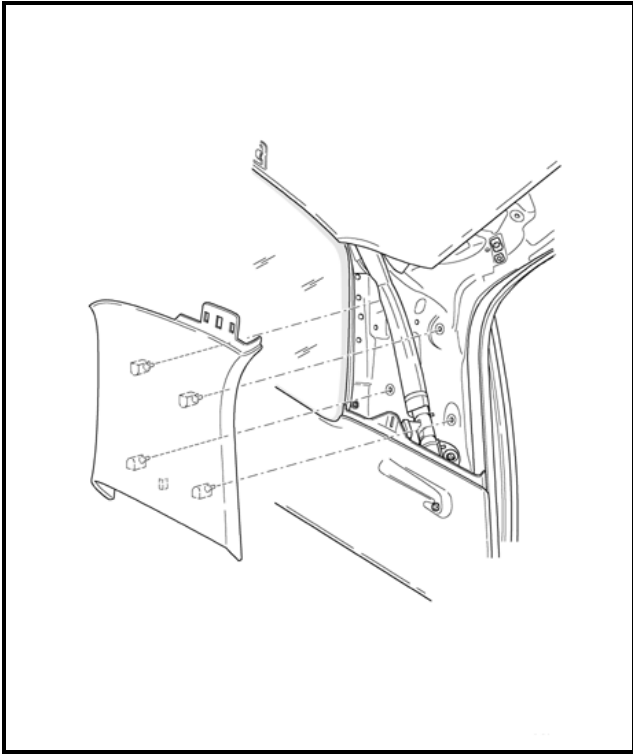

⇐ Pull D-pillar trim out of mountings in body and door seal molding

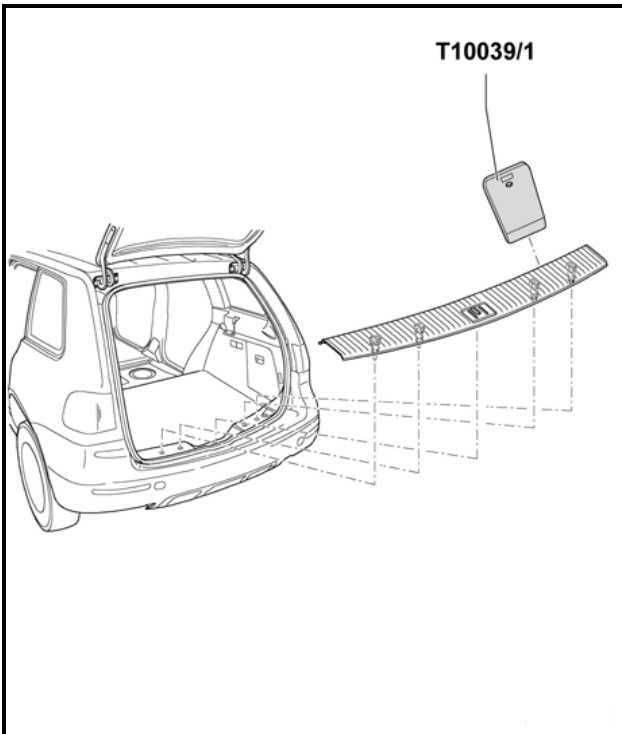

⇐ Open spare wheel cover

⇐ Using wedge T10039/1, pry lock carrier upward out of mountings

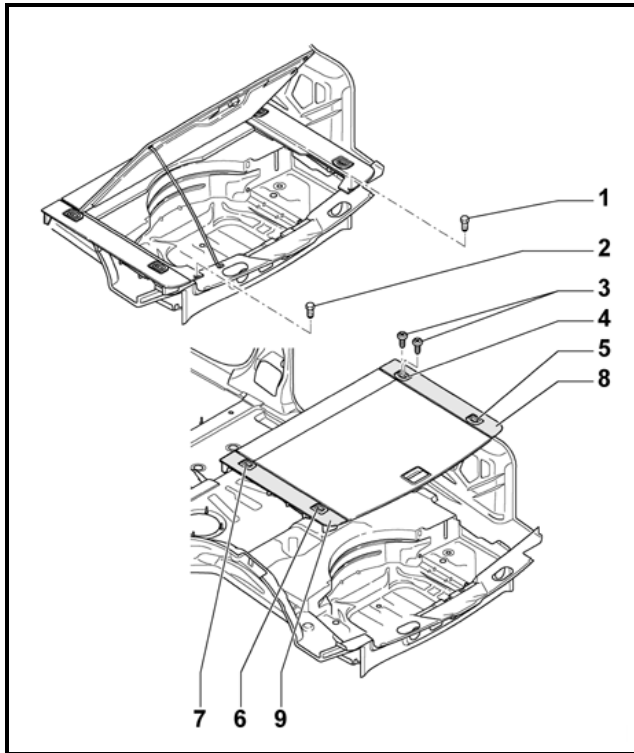

- ⇐ Remove bolts -1- and -2-
- Close spare wheel cover
- ⇐ Remove 2 bolts -3- and remove securing eye -4-
- ⇐ Remove securing eyes -5-, -6- and -7-
- ⇐ Remove spare wheel cover, right cover support -8- and left cover support -9- from the vehicle

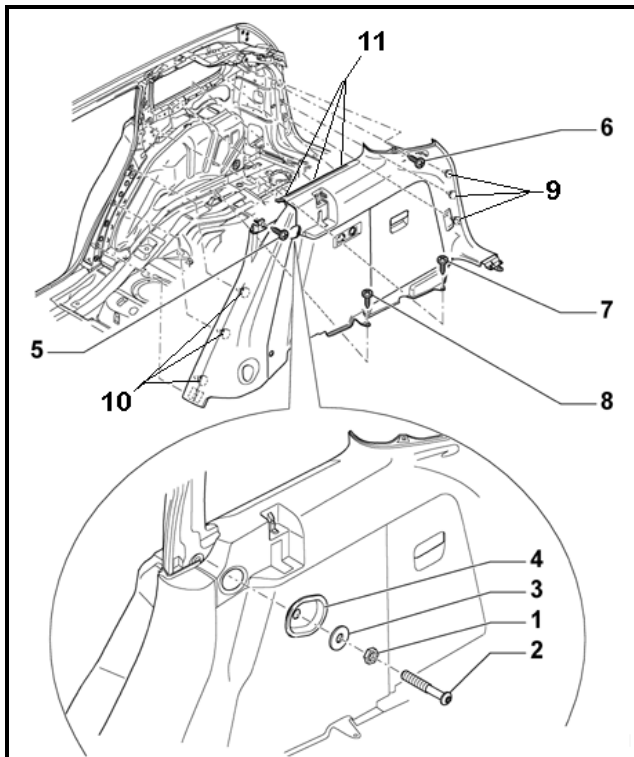

- ⇐ Loosen lock nut -1- and remove locking pin -2-
- ⇐ Remove washer -3- and trim -4-
- ⇐ Remove bolts -5-, -6-, -7- and -8-
- ⇐ Use wedge T 10039 and pull out trim panel retaining clips -9- and -10- out of holes in body
- ⇐ Carefully lift trim panel at rear and pull off of retaining clips -11-

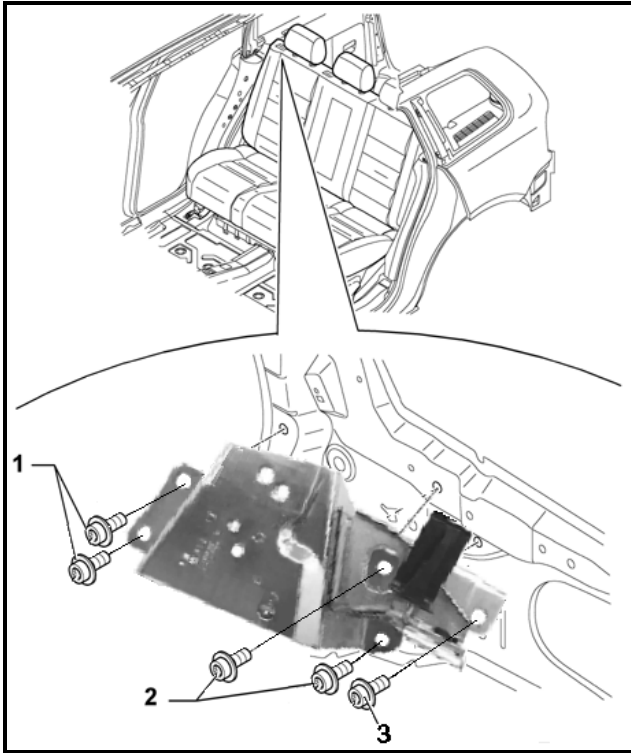

- ⇐ Remove Torx bolts -1-
- ⇐ Remove Torx bolts -2-
- ⇐ Remove hexagon bolt -3- and back rest mounting bracket

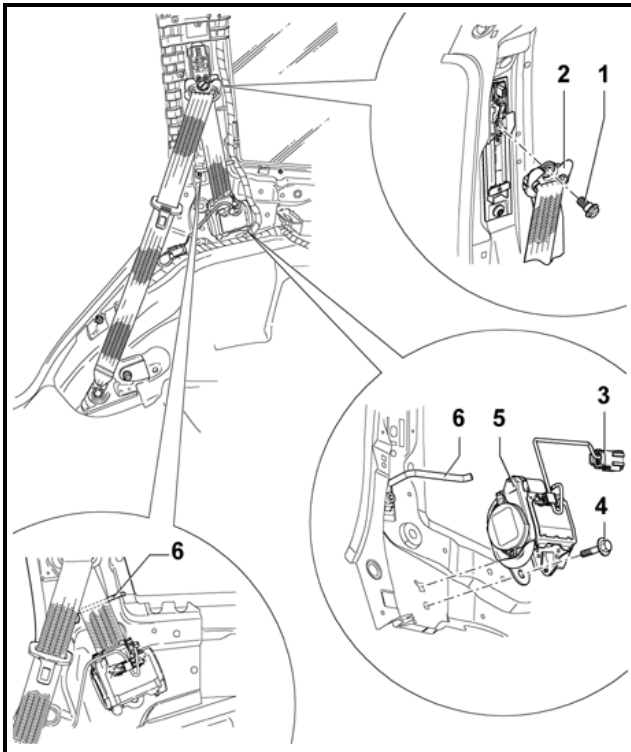

- ⇐ Remove bolt -1- and pull belt relay -2- off belt height adjuster

**! WARNING**  
 Electrostatic discharges can result in an inadvertent deployment of Airbag. Therefore, mechanic/technician must electrostatically discharge him/herself, before separating ignition and Ground (GND) wire. This is done e.g. by briefly touching body or door striker or pin.

- ⇐ Disconnect connector -3-
- ⇐ Remove bolt -4- and remove inertia reel -5- from body

## Section C – Rear Seat Belt Installation

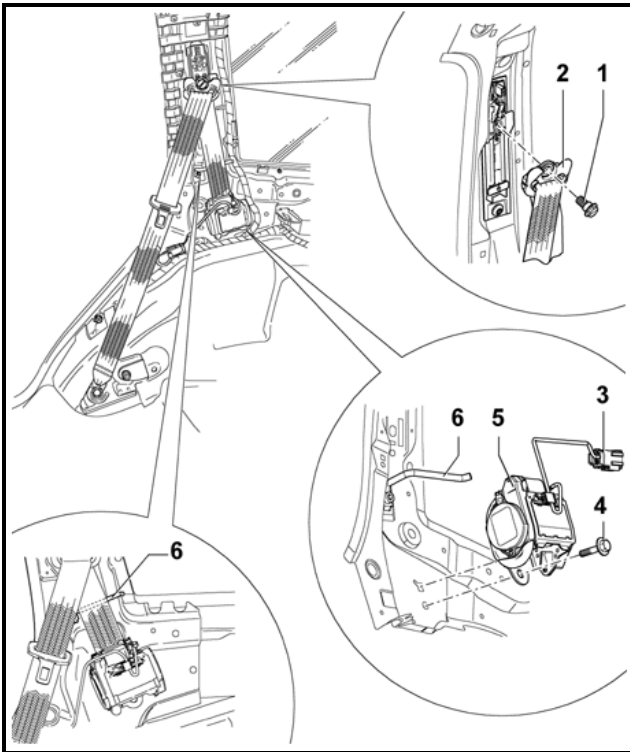

⇐ Install new seat belt (7L0 857 805A/806A dated 07.08.2004 (**7 August 2004**) or later) and using the V.A.G 1332 torque wrench, tighten bolt -4- to 50 Nm (37 ft. lbs.)

⇐ Reconnect connector -3-



### WARNING

**Electrostatic discharges can result in an inadvertent deployment of Airbag. Therefore, mechanic/technician must electrostatically discharge him/herself, before separating ignition and Ground (GND) wire. This is done e.g. by briefly touching body or door striker or pin.**

⇐ Secure belt relay -2- to belt height adjuster and tighten bolt -1- to 50 Nm (37 ft. lbs.)

Note: When installing, ensure that the belt webbing runs over belt guide -6-

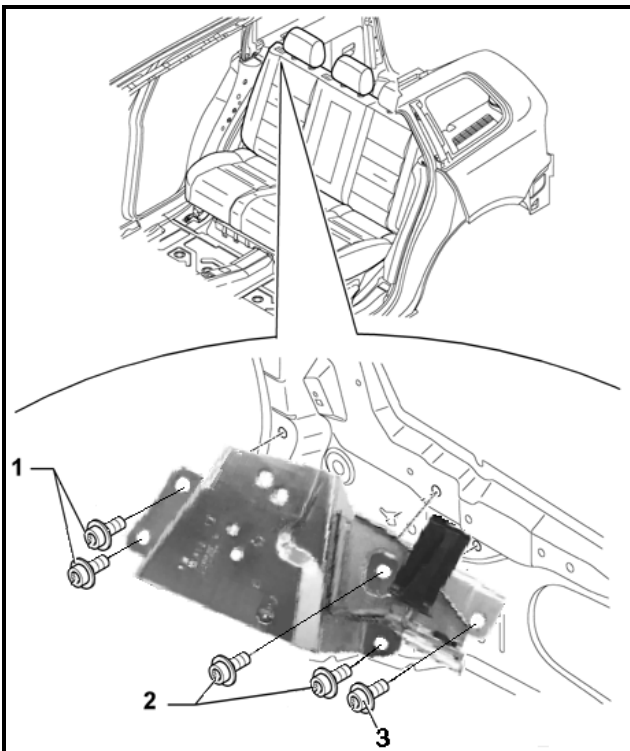

- Using a wire brush, clean the threads on bolts -1-, -2- and -3-
- Apply Loctite® threadlocker blue 242 to threads on bolts -1-, -2- and -3-

⇐ Reinstall backrest mounting bracket, secure with Torx bolts -1- and -2- and tighten to 20 Nm (15ft. lbs.)

⇐ Reinstall hex bolt -3- and tighten to 20 Nm (15ft. lbs.)

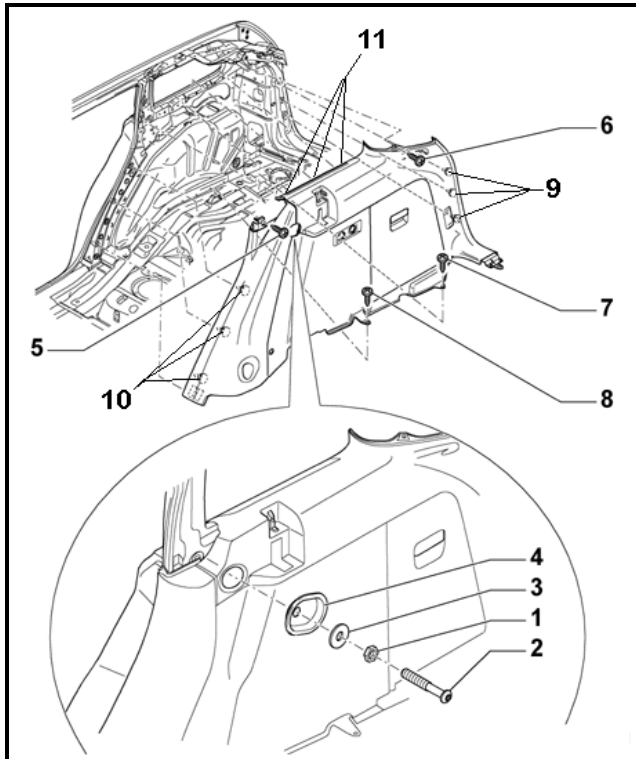

- ⇐ Reinstall side trim onto clips -11-
- ⇐ Attach side trim to body with clips -10- and -9-
- ⇐ Secure trim with bolts -5-, -6-, -7- and -8-
- ⇐ Reinstall trim -4- and washer -3-
- ⇐ Reinstall locking pin -2- and tighten lock nut -1-

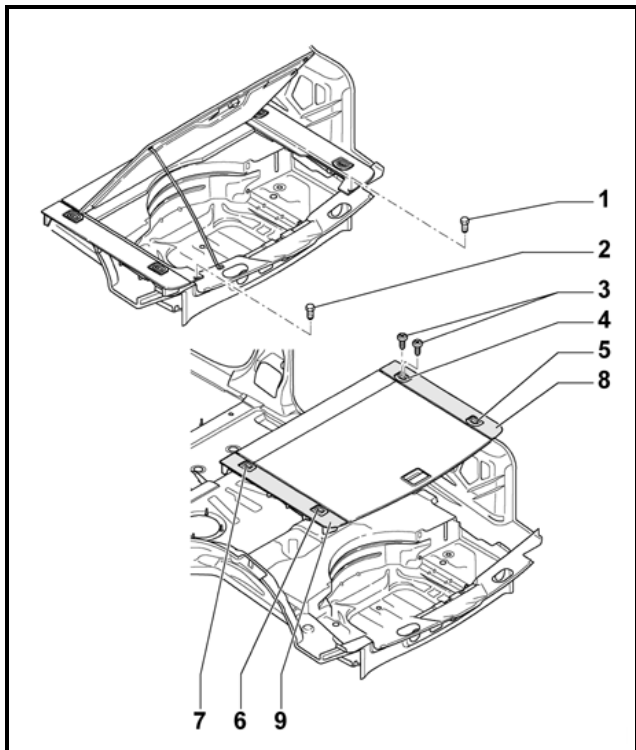

- ⇐ Reinstall right cover support -8- and left cover support -9-

Note: Align components before bolting them so that the gap size is equal all around

- ⇐ Reinstall securing eyes -5-, -6- and -7-
- ⇐ Reinstall securing eye -4- and 2 bolts -3
- ⇐ Reinstall bolts -1- and -2-
- Reinstall lock carrier mounting
- Reinstall D-pillar trim
- Reinstall roof end strip

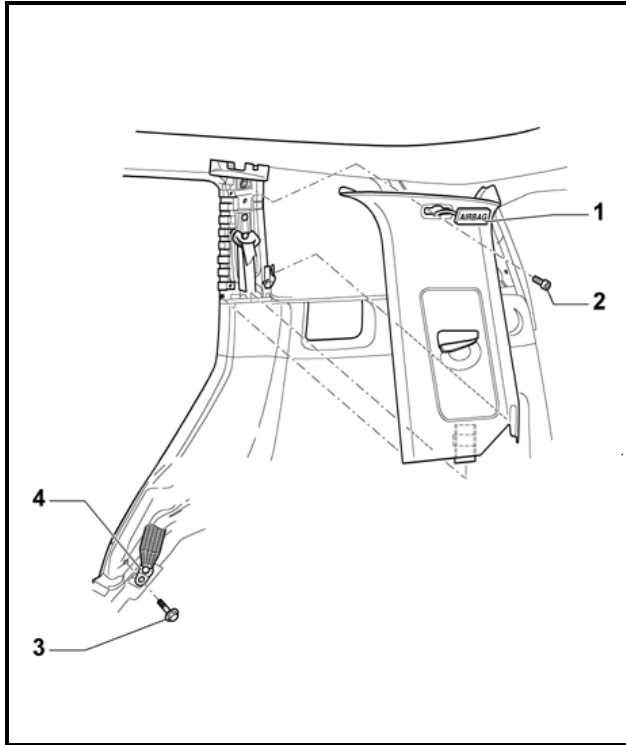

**NEW**



- Pull seat belt through opening and reinstall trim into mountings in body and door seal molding

Note: When installing trim, do not press belt height adjustment button

During installation, attach trim from bottom upwards towards belt height adjuster

⇐ Position seat belt anchor -4- on body and secure with bolt -3- and tighten to 50 Nm (37 ft. lbs.)

⇐ Secure trim with screw -2- and cover with air bag emblem -1-

- Reconnect batteries and tighten bolts to 9 Nm (80 in. lbs.)
- Perform battery restoration procedure
- Render removed belt inoperative by cutting belt webbing; properly dispose of removed belt(s) in accordance with your state and local regulations.

## WORK IS COMPLETE

### Section D – Install Bracket and Locking Clamp on Rear Seat Belts

Note: All illustrations in this section show the right side of vehicle



⇐ Tilt the rear seat bottom forward and pull the rear seat belt out approximately 90 to 100 cm (35 to 40 in.)



- ⇐ While holding the seat belt pulled out, slide the seat belt tongue along the belt and carefully wedge it between the rear seat back and the C-pillar trim to prevent the seat belt from retracting



- ⇐ Lay the seat belt flat on the vehicle floor without twisting the belt
- ⇐ Locate the mid-point approximately halfway between the seat belt anchor point -1- and the latch stop button -2-



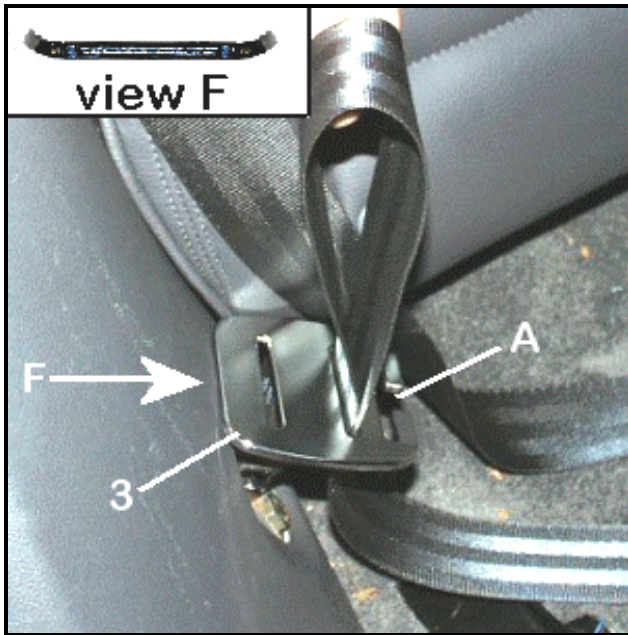

⇐ Hold bracket -3- (7L0 857 837) over the seat belt with the cut slot end -A- pointing toward the center of the vehicle and the angled sides facing upward -view F-

⇐ Insert the previously found mid-point of the seat belt into the middle slot of the bracket and pull the set belt through the slot until the latch stop button and seat belt anchor point contacts the bottom of the bracket



⇐ Fold mid-point of seat belt down and insert into outer slot of bracket

- Pull mid-point of seat belt completely through outer slot and remove any slack while making certain the bracket is still tight against the latch stop button and seat belt anchor point



⇐ Fold the seat belt over the top of the bracket and insert seat belt through the cut -A- and into the slot then spread seat belt completely across the slot and over outer edge

- Make certain the seat belt is centered over the slot and outer edge



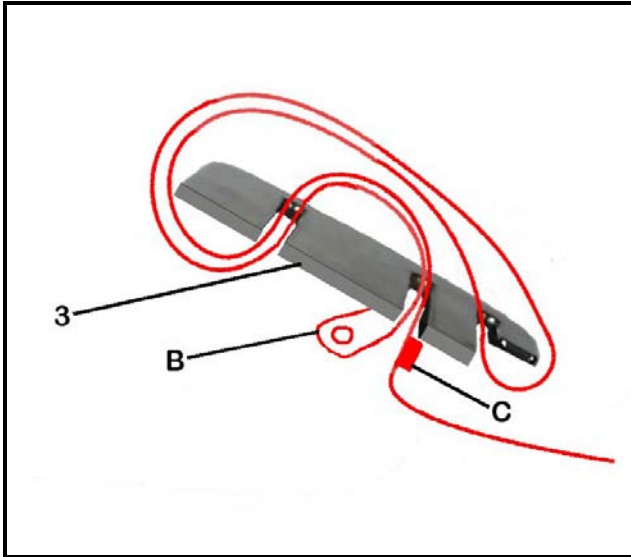

⇐ Reference illustration showing seat belt routing in bracket

- Bracket -3- is shown cut in half for illustrative purposes
- Seat belt anchor point -B-
- Seat belt latch stop button -C-



⇐ Slide the locking clamp -2- across the bracket between the seat belt and the cut slot end

- Squeeze the locking clamp together with your fingers until it locks together over the cut slot end

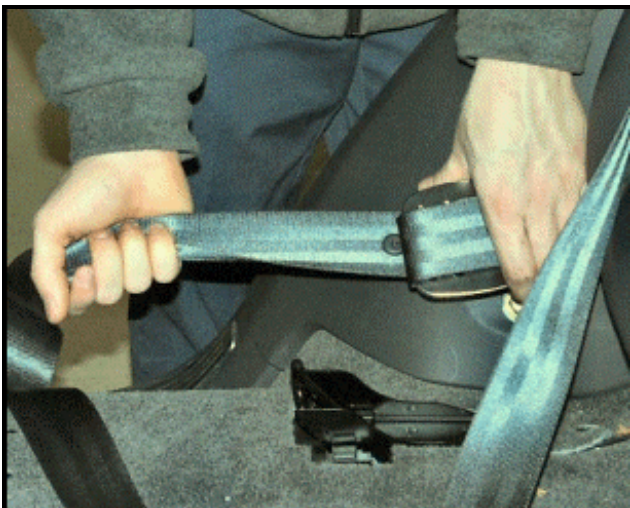

⇐ Hold the bracket in one hand pull the seat belt until the slack has been removed

- Remove seat belt tongue from area between seat back and C-pillar trim

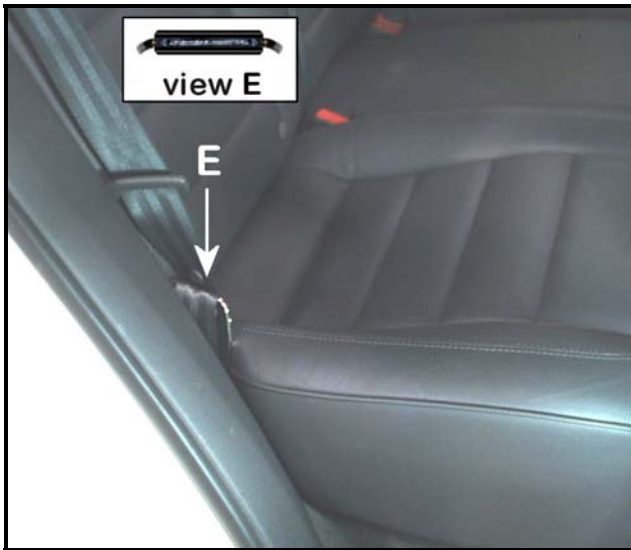

- Reposition rear seat bottom
- ⇐ The bracket should be located close to the seat belt anchor point with the latch stop button visible above it and the angled sides of the bracket are pointing outward -view E-
- Repeat procedure for opposite side seat belt