

Fits following cars:
 Golf4 / Jetta4 / Bora / Audi TT / A3 / S3 (8L)
 VR6 / V6 / 12v / 24v / R32 / 3.2 1.8T / 2.0
 Not DSG

VW / AUDI type 4 chassis Transmission Side Mount (US-Driver side), 4 / 6 CYLINDER MODELS

Fitting notes:

- 1) **WARNING: DO NOT LOOSEN OFF ENGINE MOUNTING BOLTS IF ENGINE IS NOT SUPPORTED FROM BELOW.**
- 2) **IF YOU ARE INSTALLING BOTH SIDE MOUNTS: ONLY INSTALL ONE SIDE MOUNT AT A TIME. THIS PREVENTS MISALIGNMENT OF THE ENGINE IN THE LEFT-TO-RIGHT AXIS.**
- 3) Support engine from below. You will need to remove the airbox and loosen off the wiring harness guide that's runs over the mount. Loosen off and remove the Engine side mount.
- 4) Fit the new VF mount exactly in place of the original mount. All holes should line up and the mount edges should sit parallel to the OEM casting. Using new bolts secure mount and torque as below.
- 5) The VF mount is provided with a black brace: secure this to the brace from the top of the VF mount to the body as per bolt #2 below.
- 6) Check torque settings after 200 miles. IF IN DOUBT CONSULT WORKSHOP MANUAL / VF-TECHNICAL. DO NOT INSTALL THIS PART WITHOUT USING A TORQUE WRENCH.

- Bolt 1 - Mount to Body bolt **40Nm (30 ft-lbs)**
 Bolt 2 - Mount bracket to body bolt **25Nm (18 ft-lbs)**
 Bolt 3 - Mount to engine bracket bolt **60 Nm (44 ft-lbs)**
BOLT IN CENTER OF VF-MOUNT TO BE TORQUED TO 40Nm (30 ft-lbs)

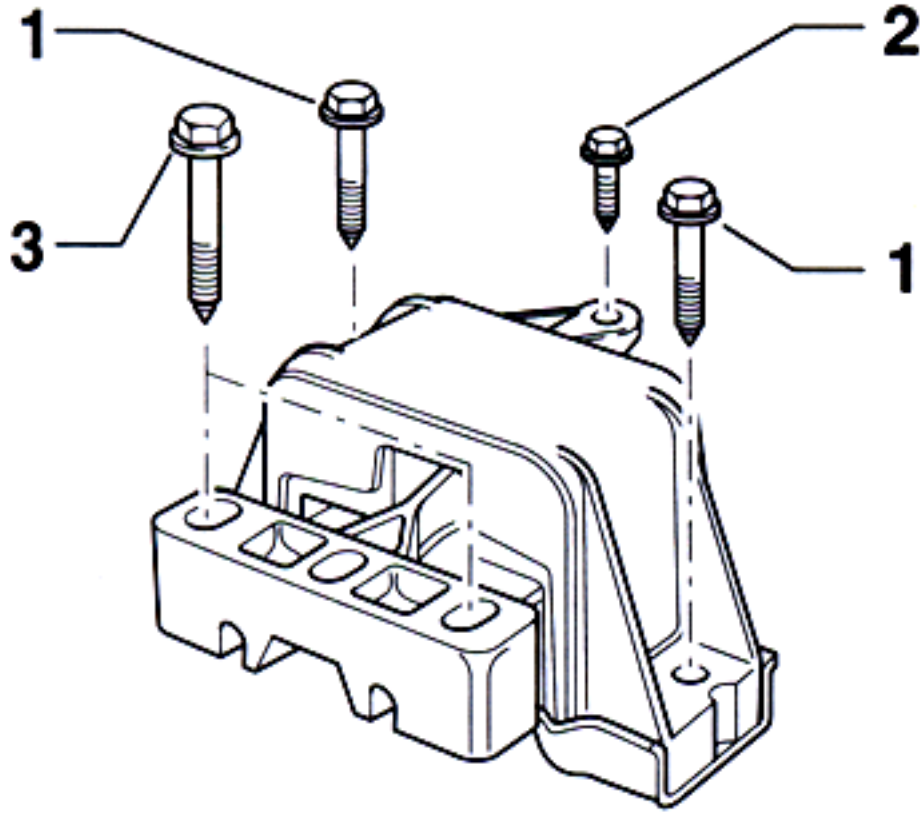

Warranty: 12 months or 12,000 miles whichever occurs sooner on defective parts only. No liability is accepted for misused or misfitted parts. For off-road use only. If in doubt do not fit part and consult retailer.

	MANF BY	Zurich Engineering, Inc. www.vf-engineering.com
	22 OCT 04	
TOLERANCE		VF PART #VFA02-04
DRAWN	MFG ENG	

THE PRODUCT AND INFORMATION SUPPLIED IS THE SOLE PROPERTY OF ZURICH ENGINEERING, INC. ANY REPRODUCTION IN PART OR WHOLE WITHOUT THE WRITTEN PERMISSION OF ZURICH ENGINEERING, INC. IS PROHIBITED.