

MasterSheet

027 0016
Revision 05/09/12



Complete Car Audio
Installation Instructions
CRUTCHFIELD™

**1997-2002
Jeep Wrangler**

IMPORTANT

Before starting, compare items on your invoice with items received. Carefully check through packaging material. If any item is missing, please call **Crutchfield Technical Support at 1-800-955-9094**.

Although reasonable attempts are made to verify the accuracy of the information contained in this MasterSheet, it is presented without warranties or guarantees of any type due to the constantly changing nature of this type of information and running changes in vehicle production. Any person or entity using this information does so at his or its own risk. If you find our instructions are different from your vehicle, or if you have questions, do not continue with your installation. Contact our toll-free technical support for assistance.



0000270016

Inside...

Page

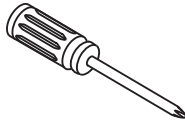
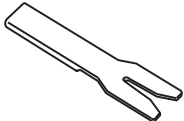
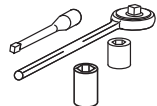
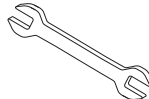
2-3	Factory Radio Removal	✓	✓	✓	✓	✓
4	Receiver Installation	✓		✓		
5	Dash Speakers	✓		✓		
6	Rear Speakers	✓				
		Phillips Screwdriver	Panel Tool	3/8"	10mm '99 & Up	3/8" Wrench Mid '99-& Up
				Socket, Ratchet & Extension		
Tools Required ▶						

* If you need additional wiring information, visit us online at www.crutchfield.com/support/faq.html

Note: At this time, no aftermarket antenna is available from Crutchfield. A replacement antenna may be purchased from a local dealership.

CRUTCHFIELD®
CRUTCHFIELD.COM

Copyright 2012 Crutchfield Corporation

027 0016

Factory Radio Removal

Note:
1997 through mid '99 -- Use steps 1 through 7 below.
Mid 1999 and up -- Use all steps below, then continue with steps on the next page.

1. Before proceeding, eject cassette or CD from factory unit if present.
2. Set parking brake and disconnect negative battery cable to prevent any electrical short.
3. Pry along entire edge of **dash top trimpanel** to release retaining clips. Remove panel.
4. Remove ashtray and one (1) phillips screw from within **ashtray cavity**.
5. Remove two (2) phillips screws at top of **receiver/climate control trimpanel**. Pry out at bottom and top of trimpanel to release retaining clips and remove trimpanel.
6. Remove two (2) 3/8" screws securing **factory radio** to dash.
7. **1997-mid '99:** Pull out radio and remove one (1) 3/8" bolt securing ground strap. Disconnect harnesses, antenna lead and remove radio.

Mid 1999 and up: These vehicles have factory radios secured to a rear support bracket.
Continue with instructions on the next page to remove radio.

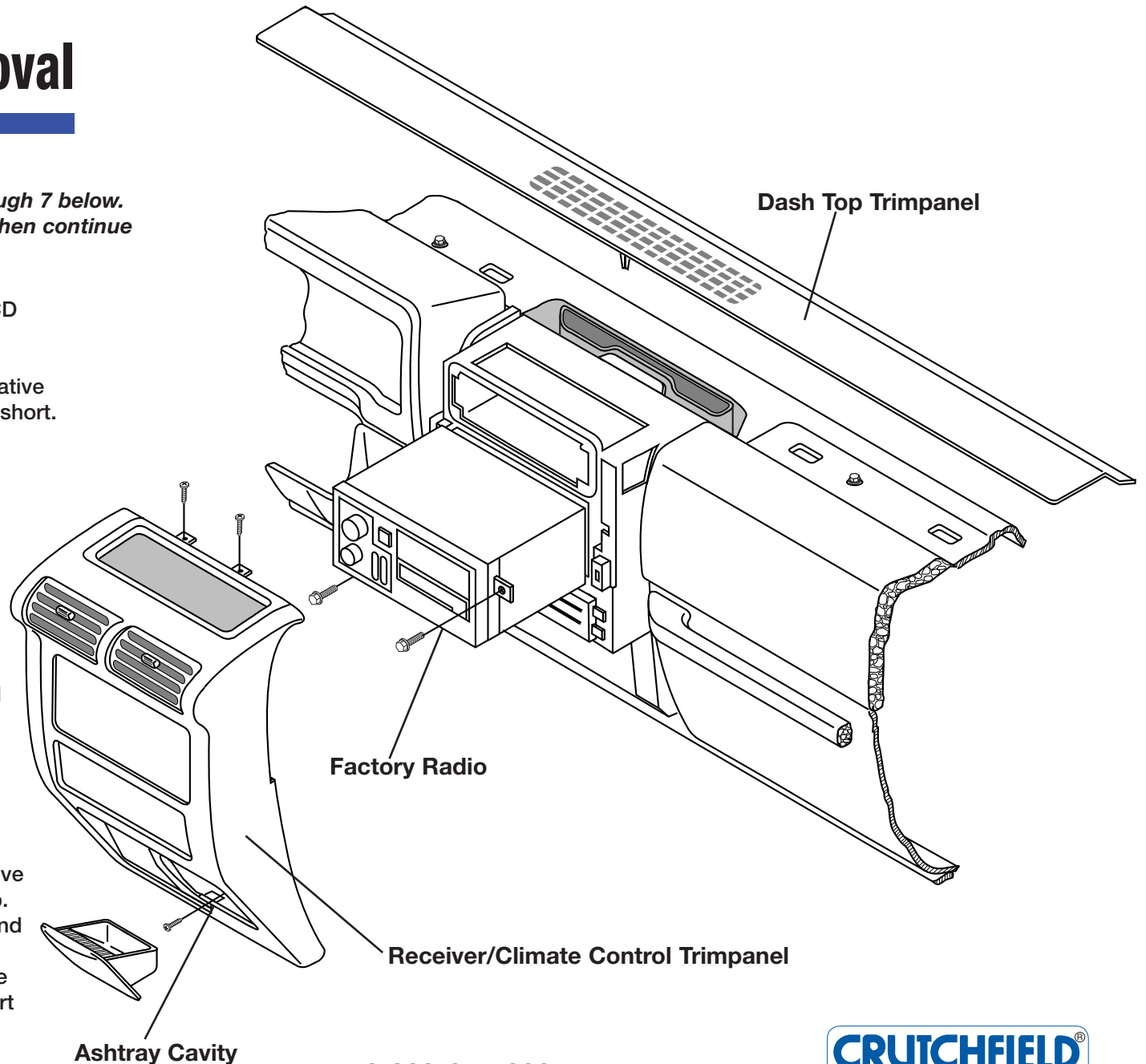

1-800-955-9094
TECHNICAL SUPPORT

CRUTCHFIELD
CRUTCHFIELD.COM

Copyright 2012 Crutchfield Corporation

027 0016

Factory Radio Removal -- Mid 1999 -

8. Remove four (4) phillips screws securing temperature control unit (Figure 1). Pull out unit and allow it to hang.

9. Reach through temperature control cavity, then reach up to locate 3/8" bolt (Figure 2) securing factory radio to rear support bracket (shown in Figure 4) at rear center of radio.

Note: The bolt also secures the ground strap to the radio. The strap will be used as ground for the new receiver. Remove bolt/ground strap (Figure 2).

10. Remove two (2) 3/8" screws securing factory radio. Pull out radio, disconnect and remove (Figure 3).

Note: If the receiver to be installed has a depth greater than six inches, the factory rear support bracket must be removed from the dash cavity. If the new receiver depth is six inches or less, it is not necessary to perform the next step.

11. Through openings in top of dash, remove two (2) 10mm nuts securing rear support bracket. Lift bracket and pull out of dash through space between subdash structure and air duct (Figure 4).

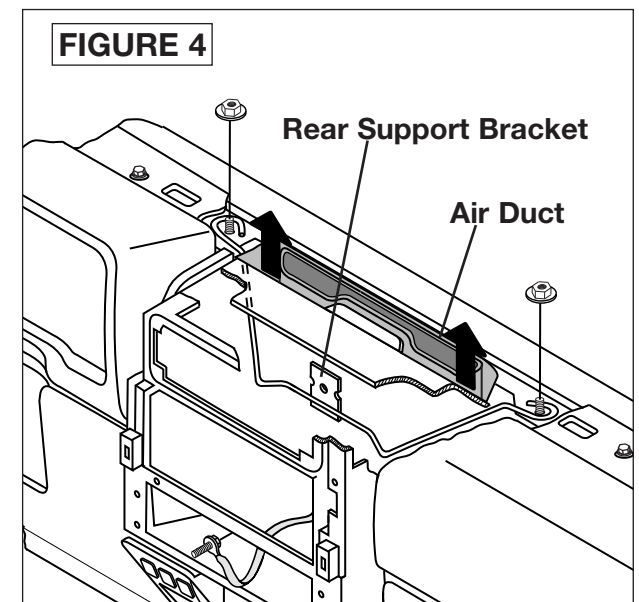
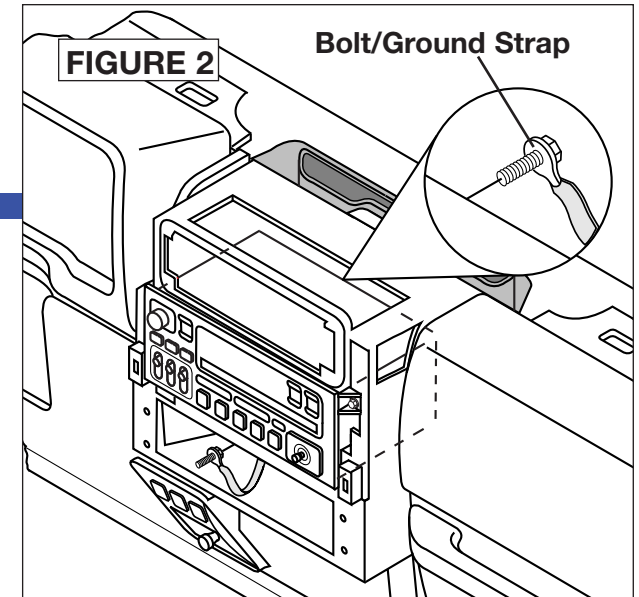
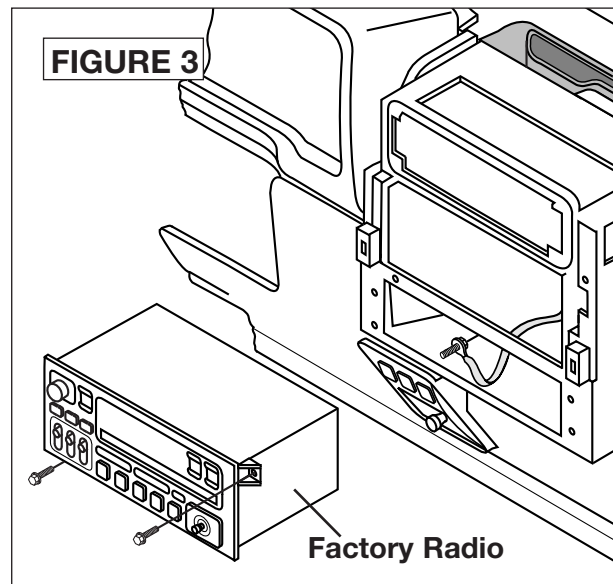
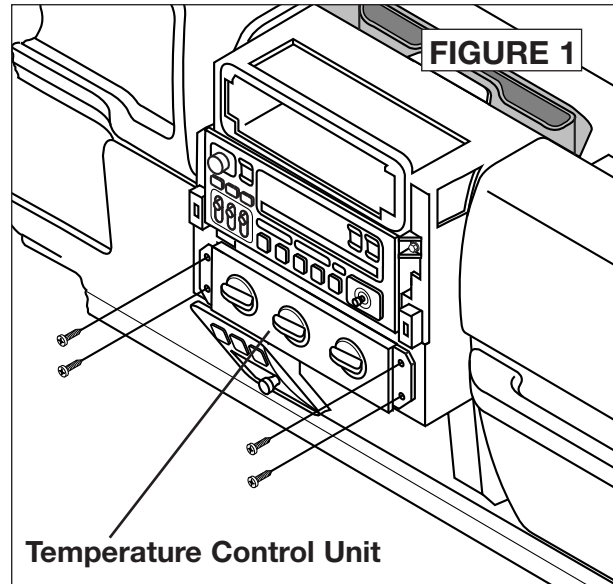

027 0016

Receiver Installation

NOTES:

Please read first

- *Inspect factory receiver harness connector in vehicle. Ensure that the wiring adaptor received from Crutchfield plugs into the vehicle's connector. If the connector is missing or incorrect, please call our Technical Support Department at **1-800-955-9094**.*

A Standard DIN unit is shown. A factory size unit may also be installed following these same steps beginning with step 2.

1. Secure receiver to installation kit following instructions supplied with installation kit.
2. Connect receiver wiring adaptor to receiver following instructions supplied with wiring adaptor.
3. Hold receiver assembly near dash. Connect adaptor harness to factory harness. Plug antenna lead into rear of receiver and secure ground strap.
4. Slide assembly into dash opening. Secure assembly to dash using the two (2) 3/8" screws removed during removal steps.
5. Test receiver operation and reinstall dash trimpanels by reversing removal steps.

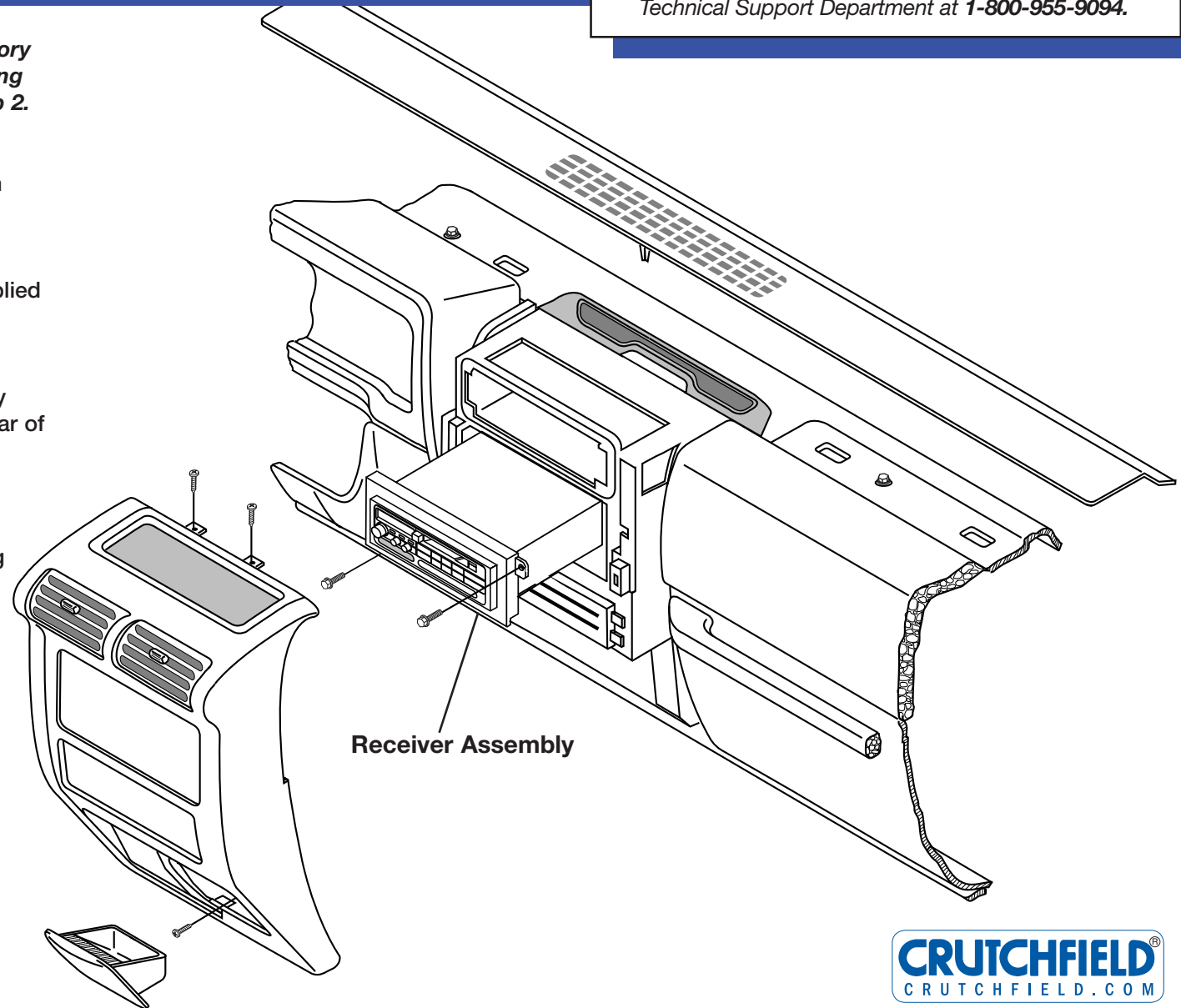

1-800-955-9094
TECHNICAL SUPPORT

CRUTCHFIELD
CRUTCHFIELD.COM

Copyright 2012 Crutchfield Corporation

027 0016

Dash Speakers

NOTES:

Please read first

- *Instructions show factory size speakers or speakers with adaptor brackets only. Cutting or fabrication (not shown) will be required for other speaker sizes.*

1. Remove two (2) phillips screws from outside edge of **speaker grille**. Pull grille straight back to release retaining clips. Remove grille.
2. Pull out **factory speaker baffle** to expose screws securing factory speaker.
3. Remove four (4) phillips screws securing speaker. Pull out speaker, disconnect and remove.
4. Secure replacement speaker to speaker adaptor bracket following instructions supplied with adaptor bracket.
5. Connect speaker wiring adaptor of replacement speaker to vehicle speaker harness. Secure **speaker/bracket assembly** to dash using screws previously removed.
6. Test speaker operation and reinstall speaker baffle and grille.

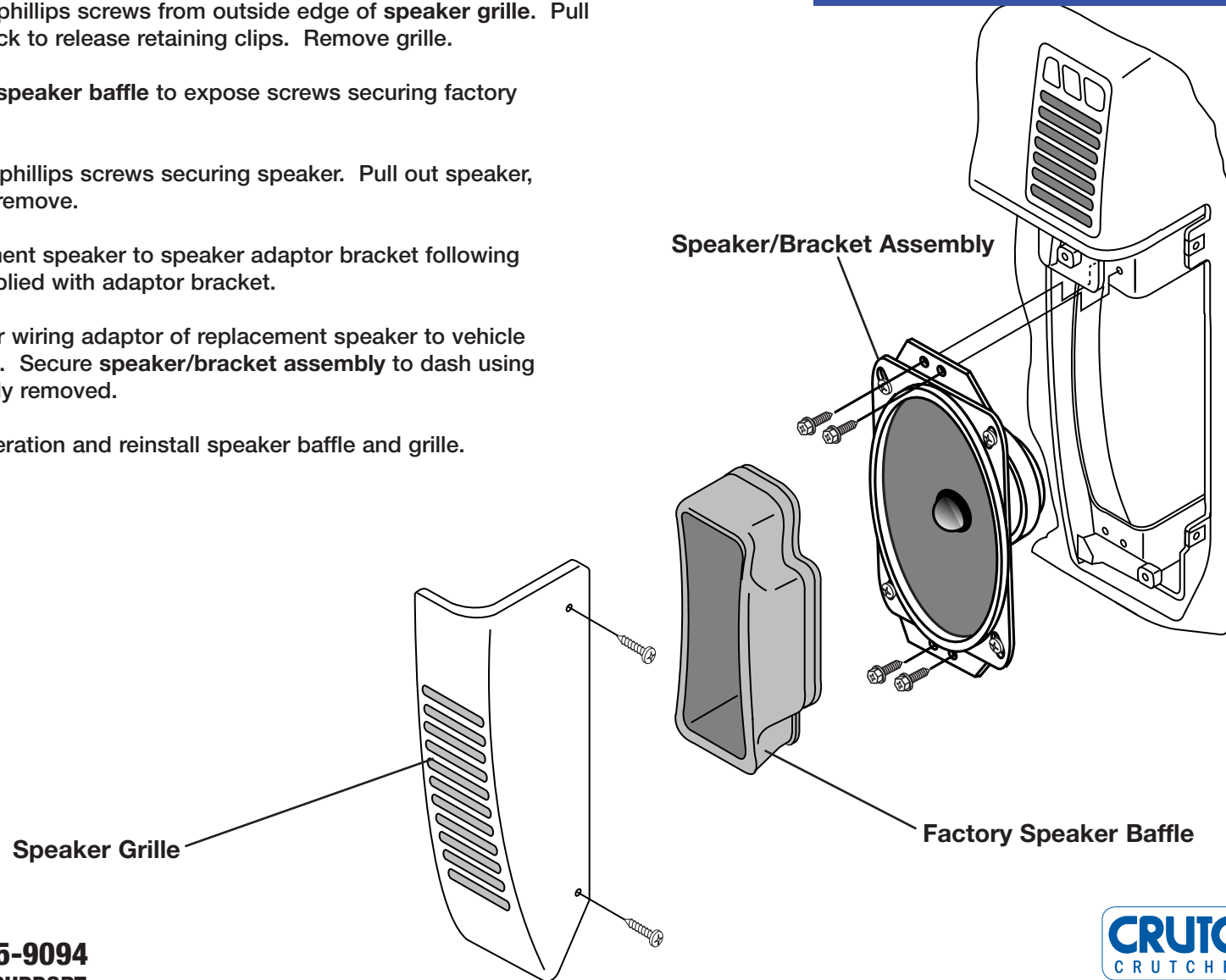

027 0016

Rear Speakers

NOTES:

Please read first

- Instructions show factory size speakers or speakers with adaptor brackets only. Cutting or fabrication (not shown) will be required for other speaker sizes.

1. Remove four (4) phillips screws from factory speaker grille. **Note:** Four (4) spacers will fall out when grille is removed.
2. Pull out speaker, disconnect and remove.
3. Connect speaker wiring adaptor of replacement speaker to vehicle speaker harness. Secure speaker and grille to enclosure using screws and spacers previously removed.
4. Test speaker operation.

