

DESCRIPTION: ELECTROPNEUMATIC HORN – HIGH AND LOW TONE

PN: 6602023

Main specifications and performances / Principali caratteristiche

Nominal voltage / Voltaggio nominale	12	Vdc
Voltage range / Voltaggio di utilizzo	11,5-13,8	Vdc
Current consumption / Assorbimento	17	A
Sound pressure level / Livello sonoro	116 (2m)	dB(A)
Frequency 'L' / Frequenza tono basso	655	Hz
Frequency 'H' / Frequenza tono alto	828	Hz
Operating temperature / Temp. di utilizzo	-30° to +80°	°C
Storage temperature / Temp. stoccaggio	-30° to +80°	°C
Corrosion resistance / Resist. alla corrosione	> 480 (salt spray test)	Hours
Operating relative humidity / Umidità di esercizio	30 to 80	%
Durability (1 sec ON, 4 sec OFF) / Durata	>50 000	Cycles
Continuous blowing	> 3	min
Electrical insulation / Isolamento elettrico	500	Vdc
Vibration (30 min, 3 axis) / Vibrazioni	1	g
Weight / Peso	1020	gr
Compressor main materials / Principali materiali compressore	Steel, Aluminum, Copper, ABS	
Trumpet main materials / Principali materiali trombe	PP, Steel, ABS	
Main applications / Principali applicazioni	Cars, Trucks	

Dimensions (mm) / Dimensioni (mm)

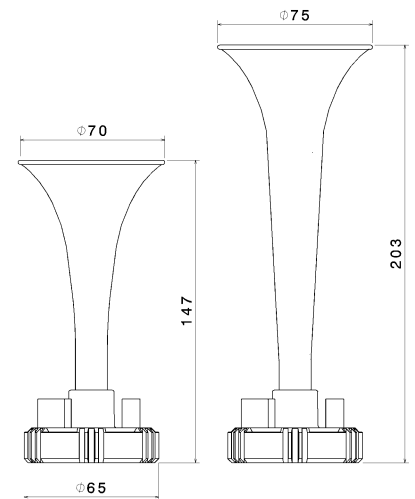

Available Electrical Connection / Connessioni elettriche disponibili

Two Terminals 6,3x0,8 mm / 2 Spine 6,3x0,8 mm



Pneumatic connection / Connessione pneumatica

Plastic tube L=73 cm to connect the trumpets to the compressor /
Tubo di plastica L=73 cm per connetter le trombe al compressore.

Conformity to Standards of / Conformità agli Standard

PRODUCT	✓	CEE 70/388
PRODOTTO	✓	REG. 28 ECE
	✓	CEE 2009/19
	✓	REG. 10 ECE
MANUFACTURING	✓	ISO/TS 16949
PRODUZIONE	✓	ISO 9001
	✓	ISO 14001

Other specifications / Ulteriori specifiche

Mechanical connection: flat and rigid surface facing the compressor and the trumpets fixing points

Montaggio meccanico: fissare il compressore e le trombe a una superficie piana e rigida.

Horn's Protection: choose an installation area protected from heat, direct water and mud splash
Protezione: installare al riparo calore, spruzzi d'acqua e fango.

Packaging: Clam shell

Imballo: Blister

Master carton: 10 pieces

Imballo multiplo: cartone da 10 pezzi