

NEW

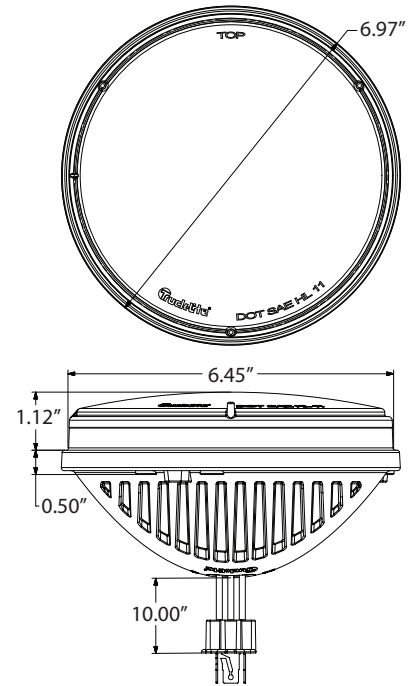
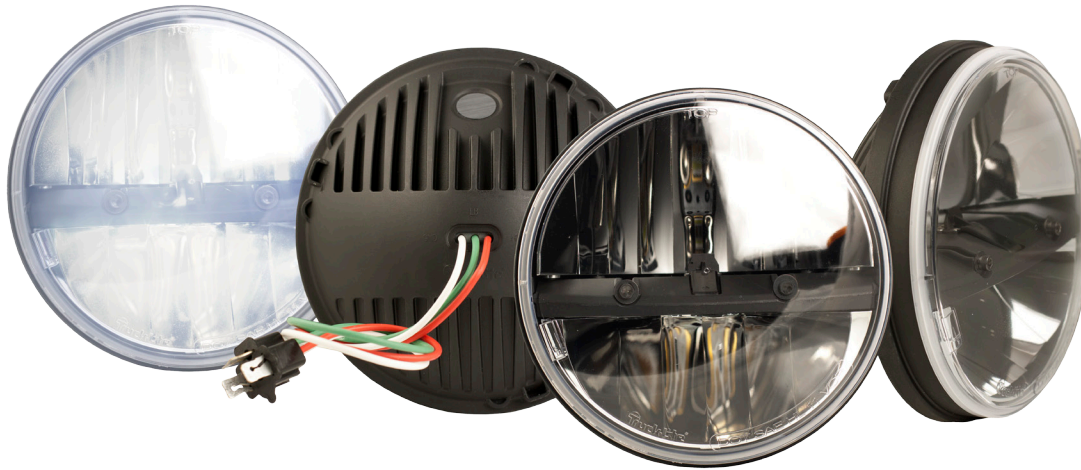

7" Round LED Headlamp

Complex Reflector Optics Design

FEATURES & BENEFITS

- When properly mounted, exceeds FMVSS-108 and CMVSS-108 DOT requirements for low beam and high beam performance
- Excellent option for light, medium and heavy-duty trucks, off-road vehicles, classic cars, motorcycles and more.
- Metalized reflector optics provide a lighting experience that's smooth and clean across the driving surface
- Provides a brighter, crisper and whiter light output, closer to the color temperature of daylight, dramatically improving light projection distance and overall visibility
- Durability and dependability of LED lighting provides a solid-state, bulb-free headlamp design that's impervious to damage from shock and vibration
- Military grade, die-cast aluminum housing and non-yellowing, polycarbonate lens offer optimum protection against damage from impact, roadside debris and other hazards
- Electronics are sealed in epoxy to resist from damage caused by corrosion or moisture
- Advanced circuitry protects against voltage spikes up to 600v
- Drop-in replacement for #6014, 6015, 6016, H6024 and Par 56 headlamp designs
- Uses standard, H4, 3-blade wiring connector
- Equipped with Truck-Lite's 3-Year Limited Warranty.

TECHNICAL SPECIFICATIONS

Material:

- Hard-coated polycarbonate lens
- eCoat aluminum housing and internal structures
- Metalized reflector
- 16 Gauge Wire

Light Source:

- 2 LED Arrays
- 9v-33v Multi-volt design works with both 12v and 24v systems
- Designed:
 - 12.8v, 1.80a (low beam), 3.60 amps (high beam)
 - 25.6v, 1.00a (low beam), 1.80 amps (high beam)

Additional Specifications:

- Operating temperature range: -40°C to 50°C
- Overvoltage protection to 600v, w/constant output
- Mechanical aim

Recommended Accessories:

- 96630 H4 to H13 adapter

PART NUMBERS

Part No.	Description	Ctn. Qty.
27270C	LED Headlamp, Multi-volt	1