

BMW 2008
The all-new M3
Sedan and Coupe



The Ultimate
Driving Machine®

The all-new 2008 M3.
Raising the bar for ultimate driving performance.



M3 Sedan and M3 Coupe Product Ordering Guide

Confidential information for use by authorized BMW centers. Please note: images shown are low resolution. Due to color monitor and printer capabilities, colors shown may not appear on screen and print out accurately. Vehicle images in this Product Ordering Guide booklet may not be U.S. spec.

Road music at up to 8400 beats a minute.

The all-new 2008 M3 Coupe and M3 Sedan's muscular new Formula 1-inspired 4.0-liter V-8 engine is a driving enthusiast's dream, capable of an astonishing 414 hp, and a redline of 8400 rpm. The M3's intelligent lightweight construction, from aluminum suspension to the Coupe's carbon-fiber roof, contributes to its responsive sporty road feel.

Add the optional Technology Package to bring the M3 to its full potential: M Drive allows you to program your preferred driving performance settings through buttons located on the center console next to the gear shift. EDC (Electronic Damping Control)¹ calls up Comfort, Normal or Sport settings to provide a choice of ride quality. And Comfort Access offers convenient keyless entry and engine start-up.

¹ EDC available as a stand-alone option, or as part of the Technology Package. DSC Off and Power Buttons are standard.



European models shown.





European models shown.

Form follows high-performance function.



The M3 Coupe's carbon-fiber roof reduces weight and lowers the center of gravity, minimizing body roll and enhancing grip through turns. (Note: not available with optional moonroof, which requires a steel roof.) Wheel-well extensions accommodate the M3's wider stance; the flat underfloor and rear spoiler lip improve its aerodynamic efficiency.

The M3 Sedan adds the convenience of two rear doors, but gives up nothing in terms of performance. M quad polished stainless-steel exhaust tips and 18" M-style alloy wheels are standard; options such as four exclusive M Metallic color choices, as well as 19" wheels further contribute to the M3's daunting appearance.



Step inside,
and prepare for takeoff.



Like the cockpit of any track-worthy vehicle, the M3 sports a sleek, athletic and energizing appearance. Strap into body-hugging, fully adjustable M sport seats with adjustable backrest width for better support in sharp turns. Plush Novillo Leather upholstery and luxurious trim materials, including Blue-gray Brushed Aluminum, Carbon Leather or Sycamore Anthracite Wood are all optional, and are available with the Premium Package.

For roadgoing convenience, cargo is easily stowed in an additional storage box (available in the Coupe only), located in the partition between the two rear seats. And for roadgoing peace of mind, BMW Assist™ is included in the Premium Package, and available as an option.

In the M3 cockpit, you're in total control.

Various features, such as the optional M Drive system,¹ can be accessed through the M sport steering wheel.² Programmable memory keys, which are located on the center console, provide one-touch access to an array of convenience settings. The optional Navigation system with 16:9 screen adds Real Time Traffic Information.

Enjoy your favorite soundtracks via an optional Enhanced Premium audio system, complete with 16 speakers and a high-end amplifier. Optional HD Radio™ and SIRIUS Satellite Radio offer more listening choices with amazingly clear audio quality. Or, hook up your iPod® to the optional iPod and USB adaptor for quick access to songs and playlists by using the steering-wheel buttons.²

¹ Requires optional Technology Package.

² When equipped with optional Navigation system.



European models shown.





Speed. Power.
Control.



No boundaries were set, no corners cut in designing the 2008 M3's powerful 4.0-liter V-8 engine. With 414-hp output and 295 lb-ft of torque, as well as a maximum engine speed of 8400 rpm, this V-8 catapults the M3 from 0-60 in just 4.7 seconds.¹ BMW's Double-VANOS technology ensures pinpoint-accurate valve timing, for optimal combustion at every rev range, while lowering emissions.

In keeping with M3's racing-inspired engineering, eight separate throttle butterflies operate precisely and independently, for amazingly quick throttle response. The result: breathtaking acceleration out of every turn, and on every straightaway.

¹ BMW AG test results, M3 Coupe. BMW urges you to obey all posted speed laws and always wear safety belts.

Get where you're going: driving nirvana.



The standard M3 transmission is a smooth 6-speed manual, with a heavy-duty clutch for immediate pick-up at the starting line and during shifting. The Variable M Differential Lock maximizes road grip and helps keep the rear-wheel-drive handling tight in all conditions.

When it comes to stopping power, the M3 is no less impressive. Massive 14" cross-drilled compound brakes work in conjunction with Dynamic Brake Control and a special high-performance-tuned

anti-lock braking system for reliable, responsive vehicle control in virtually any and all conditions.

The rigid, lightweight suspension and the uniquely engineered front and rear axles form the foundation of the M3's driving dynamics. The front axle, including the central subframe, the spring struts, the swivel bearings, and an additional thrust plate across the entire frame for added stability, is made primarily of aluminum. The five-arm rear axle, which is stiffer and 5.5 lbs. lighter than conventional construction, features all-aluminum dampers.

M3 Sedan and M3 Coupe Exterior Paints

Non-metallic

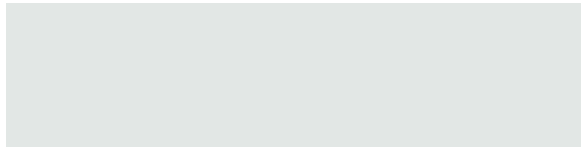

■ 300 Alpine White

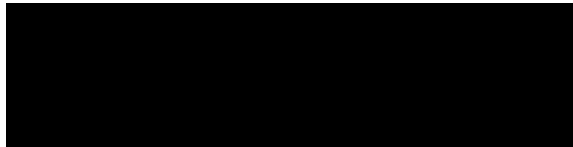

■ 668 Jet Black

Metallic



□ A22 Sparkling Graphite Metallic

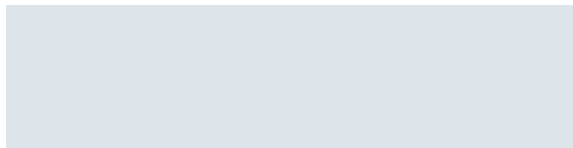

□ A29 Silverstone II Metallic



□ A30 Interlagos Blue Metallic



□ A52 Space Gray Metallic¹



□ A73 Jerez Black Metallic



□ A75 Melbourne Red Metallic

Please note: Due to color monitor and printer capabilities, colors shown may not appear on screen and print out accurately.

- Standard equipment
- Optional equipment

¹ Not available on M3 Sedan.

M3 Sedan and M3 Coupe Upholsteries



GEAT Anthracite and Black Cloth/Leather



NCH1 Silver Novillo Leather

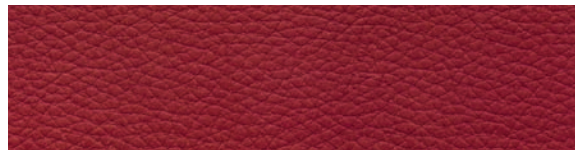

NCH2 Fox Red Novillo Leather

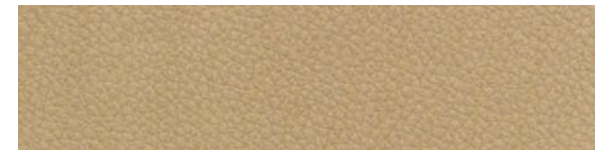

NCH3 Bamboo Beige Novillo Leather

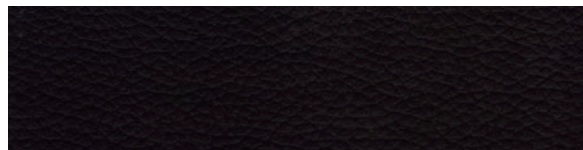

NCSW Black Novillo Leather



NDH1 Silver Novillo Extended Leather

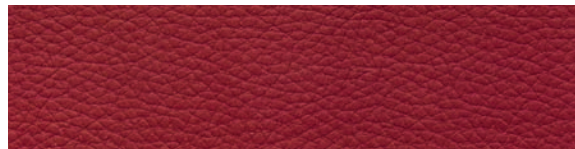

NDH2 Fox Red Novillo Extended Leather

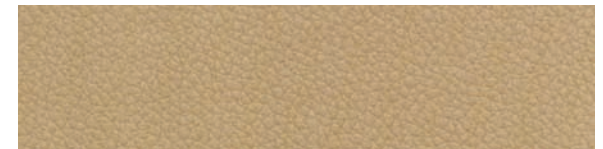

NDH3 Bamboo Beige Novillo Extended Leather

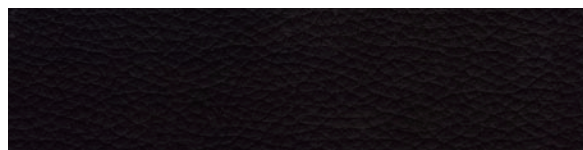

NDSW Black Novillo Extended Leather

Please note: Due to color monitor and printer capabilities, colors shown may not appear on screen and print out accurately.

- Standard equipment
- Optional equipment

M3 Sedan and M3 Coupe Interior Trims



■ 4BZ Titanium Shadow

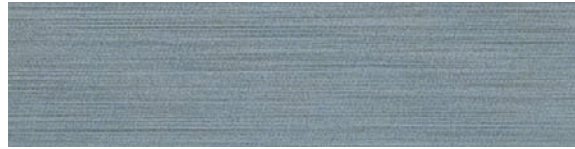

□ 4MX Blue-gray Brushed Aluminum

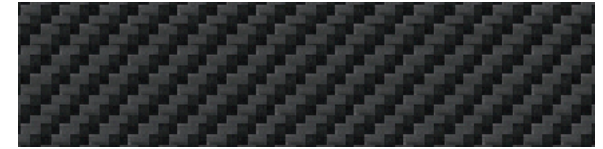

□ 4MY Carbon Leather

















□ 4MZ Sycamore Anthracite Wood

Please note: Due to color monitor and printer capabilities, colors shown may not appear on screen and print out accurately.

- Standard equipment
- Optional equipment

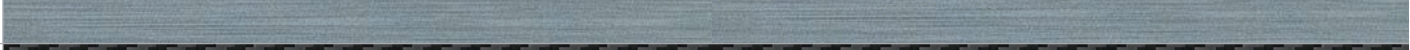

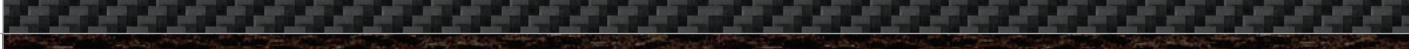
M3 Sedan and M3 Coupe Recommended Color Combinations

Materials		Cloth/Leather ■	Novillo Leather □				Novillo Extended Leather □			
Upholstery colors		GEAT Anthracite and Black	NCH1 Silver	NCH2 Fox Red	NCH3 Bamboo Beige	NCSW Black	NDH1 Silver	NDH2 Fox Red	NDH3 Bamboo Beige	NDSW Black
Exterior paints										
300 Alpine White Non-metallic ■		●	●	●	●	●	●	●	●	●
668 Jet Black Non-metallic ■		●	●	●	●	●	●	●	●	●
A22 Sparkling Graphic Metallic □		●	●	●		●	●	●		●
A29 Silverstone II Metallic □		●	●	●		●	●	●		●
A30 Interlagos Blue Metallic □		●	●		●	●	●		●	●
A52 Space Gray Metallic ¹ □		●	●	●	●	●	●	●	●	●
A73 Jerez Black Metallic □		●	●	●	●	●	●	●	●	●
A75 Melbourne Red Metallic □		●	●		●	●	●		●	●
Interior trims										
4BZ Titanium Shadow ■										
4MX Blue-gray Brushed Aluminum □										
4MY Carbon Leather □										
4MZ Sycamore Anthracite Wood □										

■ Standard
□ Optional

Please note: Due to color monitor and printer capabilities, colors shown may not appear on screen and print out accurately.

¹ Not available on M3 Sedan.

Equipment

	M3 Coupe	M3 Sedan
Performance and efficiency		
4.0-liter 32-valve 414-hp V-8 engine with M Double-VANOS “steplessly” variable valve timing	●	●
8 individual throttles, electronically controlled (drive-by-wire)	●	●
Digital Motor Electronics (DME) with on-board diagnostics	●	●
Oil coolant heat exchanger	●	●
Distributorless electronic ignition system	●	●
3-way catalytic converter with heated oxygen sensor	●	●
6-speed manual transmission with additional oil cooler and heavy-duty dual-disc clutch	●	●
Handling, ride and braking		
Dynamic Stability Control (DSC)	●	●
All Season Traction with Variable M Differential Lock	●	●
Electronic Damping Control with Comfort, Normal and Sport mode	○/■	○/■
Vehicle-speed-sensitive variable-assist power steering (M Servotronic)	●	●
M Drive with M Dynamic Mode (MDM)	■	■
M suspension with twin-joint spring-strut front axle, subframe, front axle tie-rod and stiffening plate in aluminum, rear axle subframe in steel, track control arm and spring strut in aluminum and lightweight steel construction	●	●
Gas-pressurized front struts and rear shock absorbers	●	●
Massive, 4-wheel BMW M vacuum-assisted ventilated, cross-drilled anti-lock compound disc brakes with floating brake rotors	●	●
High-performance-tuned anti-lock braking system (ABS) with Dynamic Brake Control	●	●

	M3 Coupe	M3 Sedan
Exterior and aerodynamics		
M-style alloy wheels (Style 260M) with Satin Chrome finish, 18 x 8.5 front, 18 x 9.5 rear; 245/40 front and 265/40 rear performance tires ¹	●	●
M Double Spoke (Style 220M) polished and forged light alloy wheels, 19 x 8.5 front, 19 x 9.5 rear; 245/35 front and 265/35 rear performance tires ¹	○	○
Xenon Adaptive low- and high-beam headlights with auto-leveling and Cornering Lights function	●	●
Aluminum hood with powerdome	●	●
Carbon-fiber roof ²	●	
Flared front and rear fenders, including wheel arches; vent gills in front fenders with integrated indicator and M3 logo	●	●
Front spoiler and rear Gurney spoiler	●	●
M rear apron with diffuser	●	●
Paneled underbody	●	●
High-Gloss shadowline trim	●	●
M exterior side-view mirrors in body color with double bridge in black	●	●
Heated side-view mirrors, windshield washer jets and door locks	●	●
Power folding mirrors	◇	◇
Rear-view mirror with digital compass	◇	◇
High-pressure liquid retractable headlight cleaning system	★	★
White turn-signal indicators	●	●
M quad polished stainless-steel exhaust tips	●	●
Rear spoiler deletion	○	○
Metallic paint	○	○

- Standard
- Optional
- ◇ Included in Premium Package
- ★ Included in Cold Weather Package
- Included in Technology Package

¹Due to low-profile tires, please note: wheels, tires and suspension parts are more susceptible to road hazard and consequential damages. Performance tires are not recommended for driving in snow and ice. Please note: M3 Coupe and Sedan are not equipped with a spare tire and wheel. They include M Mobility System, which offers lifetime BMW Roadside Assistance for tire assistance.

²Not available with optional moonroof, which requires steel roof.

Equipment

	M3 Coupe	M3 Sedan
Interior seating and trim		
Anthracite and Black Cloth/Leather upholstery	●	●
Novillo Leather upholstery	○/◇	○/◇
Extended Novillo Leather upholstery	○	○
Anthracite headliner	●	●
Titanium Shadow interior trim	●	●
Blue-gray Brushed Aluminum interior trim	○/◇	○/◇
Carbon Leather interior trim	○/◇	○/◇
Sycamore Anthracite Wood interior trim	○/◇	○/◇
Power-adjustable front sport seats with manually adjustable thigh support and memory system for driver' s seat and outside mirrors	●	●
Width-adjustable power front-seat backrests with 4-way lumbar support	●	●
Front seatback storage nets	●	●
Split fold-down rear seats	●	○/★
Folding rear-seat headrests	●	●
3-stage heated front seats	○/★	○/★
Adjustable front armrest	●	●
Rear-seat center armrest		●
Door sills with BMW M3 logo	●	●

- Standard
- Optional
- ◇ Included in Premium Package
- ★ Included in Cold Weather Package
- Included in Technology Package

³Optional moonroof requires steel roof; not available with carbon-fiber roof.

⁴M Drive button included with multi-function controls with Technology Package option.

	M3 Coupe	M3 Sedan
Comfort and convenience		
Multi-function remote control	●	●
Comfort Access for keyless entry and engine start-up	■	■
Automatic climate control – includes micro-filter, automatic air recirculation, left/right temperature control, temperature- and volume-controlled rear outlets, windshield misting sensor, MAX A/C, heat at rest, and recall of individual user settings	●	●
Power, glass 2-way moonroof with remote, “one-touch” operation and sliding interior sunshade	○ ³	○
Power front/rear windows with “one-touch” up/down operation	●	●
Rain-sensing windshield wipers with Automatic headlight control	●	●
Automatic-dimming inside rear-view mirror	●	●
Automatic tilt-down of passenger' s side-view mirror when vehicle is shifted into reverse gear	●	●
3-spoke, leather-wrapped multi-function M sport steering wheel with fingertip cruise, audio and (accessory) phone controls, M color stitching and tilt/telescopic adjustment ⁴	●	●
Automatic safety-belt assistant	●	●
BMW Ambiance Lighting front and rear	●	●
Courtesy lights – include fade in/fade out, actuation from remote, automatic switch-on when engine is turned off, separately controlled left/right front and rear reading lights, front footwell lighting, and illuminated vanity mirrors	●	●
Dynamic Cruise Control	●	●
Integrated 3-button Universal garage-door opener	◇	◇
Park Distance Control (rear)	○	○
Power rear-window sunshade	○	○
Manual rear side-window sunshades		○
Console valet and cupholders	●	●
Ski bag	★	★
Vehicle & Key Memory	●	●
Electric interior trunk release	●	●
Fully finished trunk with drop-down tool kit	●	●
Rechargeable take-out flashlight in glovebox	●	●

Equipment

	M3 Coupe	M3 Sedan
Audio system		
AM/FM stereo/CD audio system with 10 speakers, Radio Data System (RDS), Auto-Store, MP3 capability and 3-channel FM diversity antenna system	●	●
Enhanced Premium Sound audio system with upgraded speakers, amplification, and vehicle-speed-sensitive equalization ⁵	○	○
Pre-wiring for accessory BMW cellular phone, 6-disc CD changer, alarm system, auxiliary input and satellite radio	●	●
HD Radio™ – receive free, digital AM/FM broadcasts in clear, static-free quality sound; “multicast” FM stations; and innovative data services	○	○
SIRIUS® Satellite Radio	○	○
iPod® and USB adaptor (includes cable connector)	○	○
Instrumentation and controls		
Engine Start/Stop button	●	●
M-design instrument cluster with titanium-finish-ringed instrument dials and red needles	●	●
Service Interval Indicator with miles-to-service display	●	●
Check Control vehicle monitoring system	●	●
Tachometer with variable warning zones and oil temperature display	●	●
On-board computer – provides detailed vehicle information, including travel range on remaining fuel, external temperature (including freezing temperature warning)	●	●
M Dynamic Mode (MDM) for accessing and designating M-specific driving systems	■	■
Navigation system with 16:9 screen and Voice Command system; iDrive system with on-board computer and Controller; includes Real Time Traffic Information function (where available) and 6 programmable memory keys	○/■	○/■
Tire Pressure Monitor	●	●

	M3 Coupe	M3 Sedan
Safety and security		
Driver' s and passenger' s front airbag supplemental restraint system (SRS) with advanced technology: dual-threshold, dual-stage deployment; and front-passenger seat sensors designed to prevent unnecessary airbag deployment	●	●
Front-seat-mounted side-impact airbags	●	●
Head Protection System (HPS), front and rear	●	●
BMW' s Advanced Safety System for integrated deployment of passive and active safety features	●	●
Interlocking door anchoring system to help protect against door intrusion in side impacts	●	●
Bumper system with aluminum impact absorbers at the front, steel impact absorbers at the rear, and front-compressible elements	●	●
Adaptive Brake Lights	●	●
Automatic front safety-belt pretensioners	●	●
Child-seat automatic safety-belt locking device in rear seats	●	●
Central locking system (leaves gas filler door unlocked) and double-lock feature	●	●
Coded Driveaway Protection (prevents engine start when your key, with constantly changing electronic code, is not used)	●	●
Crash sensor with automatic door unlocking and hazard light activation	●	●
Crash sensor with Battery Safety Terminal and automatic fuel cut-off, triggered by airbag deployment	●	●
M Mobility System (includes lifetime BMW Roadside Assistance for tire assistance)	●	●
BMW Assist™with Bluetooth ® wireless technology for hands-free calling (requires BMW-approved Bluetooth enabled mobile phone), phonebook downloading and speech recognition capabilities	○/◇	○/◇
BMW Services		
BMW Ultimate Service™	●	●

- Standard
- Optional
- ◇ Included in Premium Package
- ★ Included in Cold Weather Package
- Included in Technology Package

⁵Requires optional Navigation system or Technology Package.

Packages

	M3 Coupe	M3 Sedan
Premium Package		
Power folding mirrors	◇	◇
Rear-view mirror with digital compass	◇	◇
Integrated 3-button Universal garage-door opener	◇	◇
Novillo Leather upholstery	○/◇	○/◇
Choice of: Blue-gray Brushed Aluminum interior trim; Carbon Leather interior trim; or Sycamore Anthracite Wood interior trim	○/◇	○/◇
BMW Assist™ with Bluetooth ® wireless technology for hands-free calling (requires BMW-approved Bluetooth enabled mobile phone), phonebook downloading and speech recognition capabilities	○/◇	○/◇

	M3 Coupe	M3 Sedan
Technology Package		
M Drive with M Dynamic Mode (MDM)	■	■
M Dynamic Mode (MDM) for accessing and designating M-specific driving systems	■	■
Electronic Damping Control with Comfort, Normal and Sport mode	○/■	○/■
Comfort Access for keyless entry and engine start-up	■	■
Navigation system with 16:9 screen and Voice Command system; iDrive system with on-board computer and Controller; includes Real Time Traffic Information function (where available) and 6 programmable memory keys	○/■	○/■

Cold Weather Package

	M3 Coupe	M3 Sedan
High-pressure liquid retractable headlight cleaning system	★	★
Split fold-down rear seats	●	○/★
3-stage heated front seats	○/★	○/★
Ski bag	★	★



- Standard
- Optional
- ◇ Included in Premium Package
- Included in Technology Package
- ★ Included in Cold Weather Package

Stand-alone Optional Equipment

Option Code		M3 Coupe	M3 Sedan
223	Electronic Damping Control with Comfort, Normal and Sport mode	○/■	○/■
2MT	M Double Spoke (Style 220M) polished and forged light alloy wheels, 19 x 8.5 front, 19 x 9.5 rear; 245/35 front and 265/35 rear performance tires ⁶	○	○
326	Rear spoiler deletion	○	○
MET	Metallic paint	○	○
NC_ _	Novillo Leather upholstery	○/◇	○/◇
ND_ _	Extended Novillo Leather upholstery	○	○
4MX	Blue-gray Brushed Aluminum interior trim	○/◇	○/◇
4MY	Carbon Leather interior trim	○/◇	○/◇
4MZ	Sycamore Anthracite Wood interior trim	○/◇	○/◇
465	Split fold-down rear seats	●	○/★
494	3-stage heated front seats	○/★	○/★
403	Power, glass 2-way moonroof with remote, “one-touch” operation and sliding interior sunshade	○ ⁷	○

- Standard
- Optional
- ◇ Included in Premium Package
- ★ Included in Cold Weather Package
- Included in Technology Package

⁶ Due to low-profile tires, please note: wheels, tires and suspension parts are more susceptible to road hazard and consequential damages. Performance tires are not recommended for driving in snow and ice. Please note: M3 Coupe and Sedan are not equipped with a spare tire and wheel. They include M Mobility System, which offers lifetime BMW Roadside Assistance for tire assistance.

Option Code		M3 Coupe	M3 Sedan
507	Park Distance Control (rear)	○	○
415	Power rear-window sunshade	○	○
417	Manual rear side-window sunshades ⁸		○
752	Enhanced Premium Sound audio system with upgraded speakers, amplification, and vehicle-speed-sensitive equalization ⁹	○	○
653	HD Radio™ – receive free, digital AM/FM broadcasts in clear, static-free quality sound; “multicast” FM stations; and innovative data services	○	○
655	SIRIUS® Satellite Radio	○	○
6FL	iPod® and USB adaptor (includes cable connector)	○	○
609	Navigation system with 16:9 screen and Voice Command system; iDrive system with on-board computer and Controller; includes Real Time Traffic Information function (where available) and 6 programmable memory keys	○/■	○/■
639	BMW Assist™ with Bluetooth® wireless technology for hands-free calling (requires BMW-approved Bluetooth enabled mobile phone), phonebook downloading and speech recognition capabilities	○/◇	○/◇



⁷ Optional moonroof requires steel roof; not available with carbon-fiber roof.

⁸ Power rear-window sunshades (415) are automatically added with Manual rear side-window sunshades (417).

⁹ Requires optional Navigation system (609) or Technology Package (ZTP).
CN1005265ID

M3 Coupe Technical Data

Weight		M3 Coupe
Unladen	lbs	3704

Engine		
Cylinders / valves per cylinder		8 / 4
Displacement	cu cm	3999
Nominal output / rpm	hp	414 / 8300
Max torque / rpm	lb ft	295 / 3900

Performance		
Top speed ¹⁰	mph	155
Acceleration 0-60 mph ¹¹	sec	4.7

Tires and wheels		
Tire dimensions	standard	front: 245/40 rear: 265/40
	optional	front: 245/35 rear: 265/35
Wheel dimensions	standard	front: 18 x 8.5 rear: 18 x 9.5
	optional	front: 19 x 8.5 rear: 19 x 9.5
Material	standard	alloy
	optional	light alloy

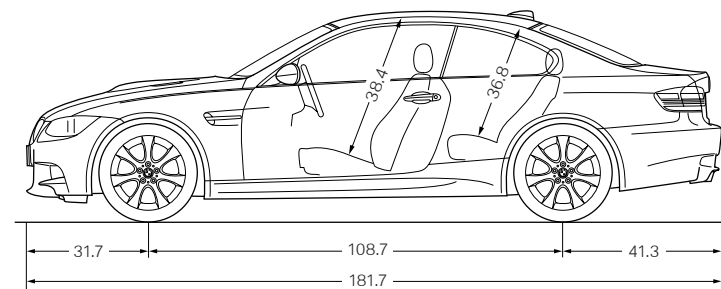
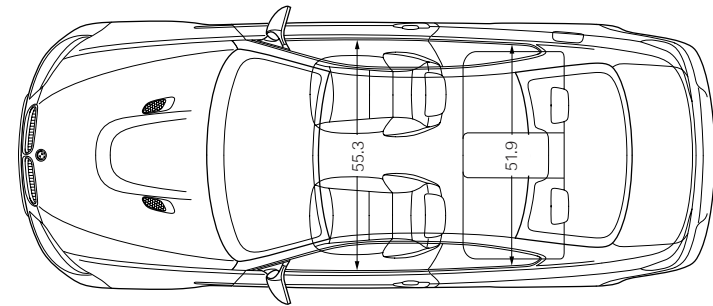
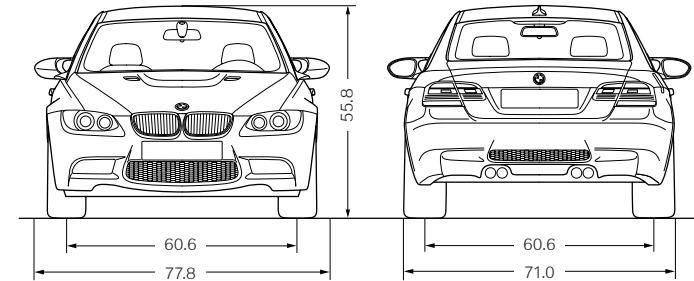

Illustrations above: all dimensions shown in inches.

¹⁰ Top speed limited electronically.

¹¹ BMW AG test results. BMW urges you to obey all posted speed laws and always wear safety belts.

M3 Sedan Technical Data

Weight		M3 Sedan
Unladen	lbs	3726

Engine		
Cylinders / valves per cylinder		8 / 4
Displacement	cu cm	3999
Nominal output / rpm	hp	414 / 8300
Max torque / rpm	lb ft	295 / 3900

Performance		
Top speed ¹²	mph	155
Acceleration 0-60 mph ¹³	sec	4.8

Tires and wheels		
Tire dimensions	standard	front: 245/40 rear: 265/40
	optional	front: 245/35 rear: 265/35
Wheel dimensions	standard	front: 18 x 8.5 rear: 18 x 9.5
	optional	front: 19 x 8.5 rear: 19 x 9.5
Material	standard	alloy
	optional	light alloy

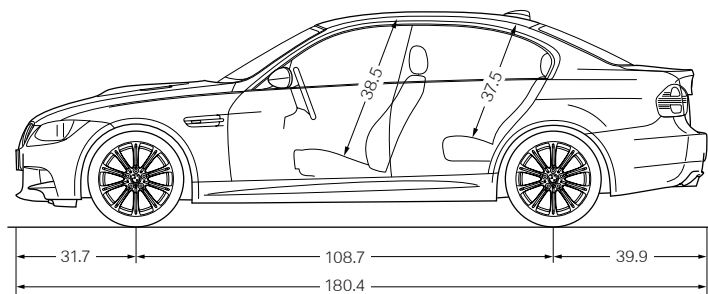
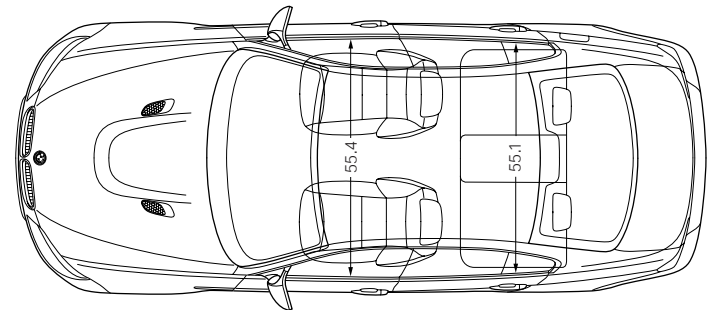
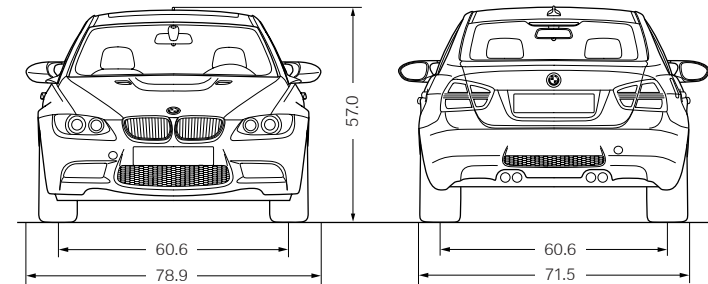

Illustrations above: all dimensions shown in inches.

¹² Top speed limited electronically.

¹³ BMW AG test results. BMW urges you to obey all posted speed laws and always wear safety belts.

U.S. Importer: BMW of North America, LLC, Woodcliff Lake, NJ 07677. All illustrations and specifications contained in this brochure are based on the latest product information available at the time of printing. BMW reserves the right to make changes at any time, without notice, in colors, materials, equipment, specifications and models. BMW may, subject to legal requirements, determine the Model Year designation of its vehicles. The Model Year designation on any particular model may be longer or shorter than 12 months. Some vehicles pictured may contain non-U.S. equipment. Some models may be shown with optional equipment. While BMW NA makes all diligent efforts to provide accurate information in this brochure, there is no guarantee or warranty of accuracy. Furthermore, we do not assume any liability for the accuracy or completeness of information presented. Further information can be obtained from bmwusa.com.

©2007 BMW of North America, LLC. Not to be reproduced wholly or in part without written permission from BMW of North America. The BMW name, model names and logo are registered trademarks. The Bluetooth word mark and logos are owned by the Bluetooth SIG, Inc. and use of such marks by BMW is under license. iPod is a registered trademark of Apple Inc. Other trademarks and trade names are those of their respective owners.

More about BMW

bmwusa.com
1-800-334-4BMW



The Ultimate
Driving Machine®



CN1005265ID