



TOYOTA

ALWAYS A
BETTER WAY

GT86

Rear trunk spoiler

Installation instructions

Model year: 2012/03

Vehicle code: ZN6-AK** ZN6-AL**





Part number:	MS342-18001-A0	Satin white pearl (37J)
	MS342-18001-C0	Crystal black silica (D4S)
	MS342-18002-00	Primered

Manual reference number: AIM 002 759-0



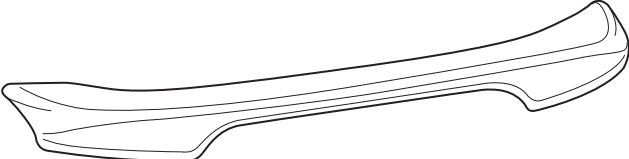

Revision Record

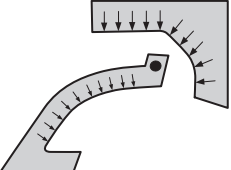



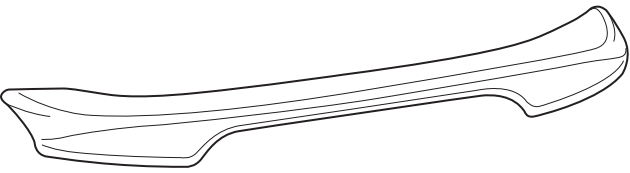
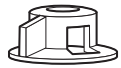

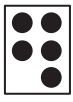
Rev. No.	Date	Page	Picture	Update	New	Deleted steps

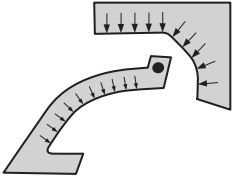
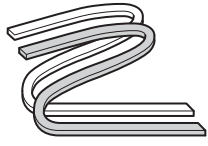
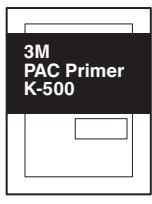
MS342-18001-A0 / MS342-18001-C0

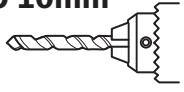
		
A 1x	B 2x	C 2x
		
D 1x	E 1x	F 1x

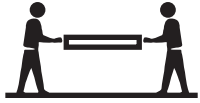
MS342-18002-00

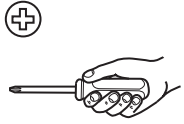
<p>A</p>  <p>1x</p>	<p>B</p>  <p>2x</p>	<p>C</p>  <p>2x</p>	
<p>D</p>  <p>1x</p>	<p>E</p>  <p>1x</p>	<p>F</p>  <p>1x</p>	<p>G</p>  <p>1x</p>
<p>H</p>  <p>1x</p>			

	<p>Ø 3mm Ø 10mm</p> 		
			

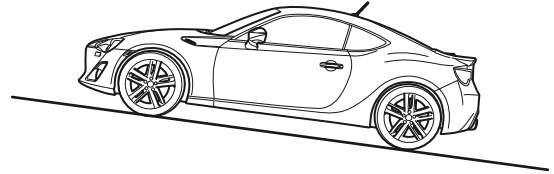
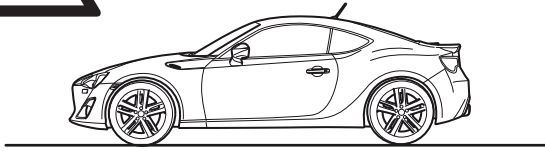

Parking

P

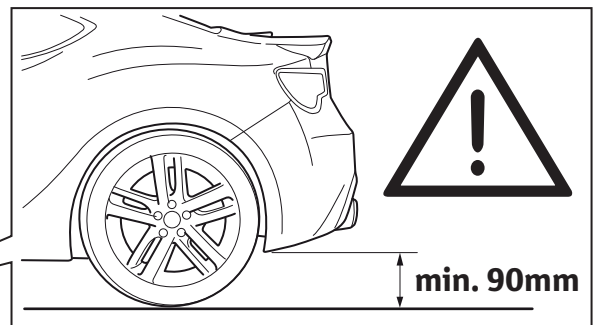
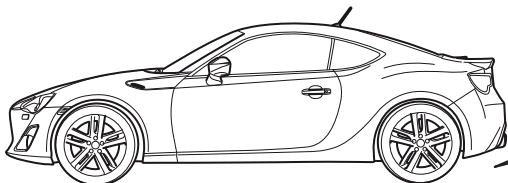
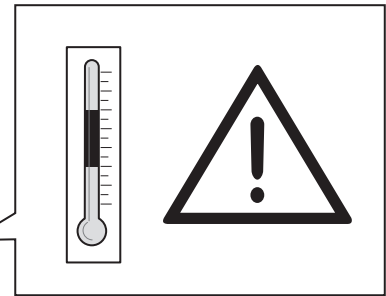
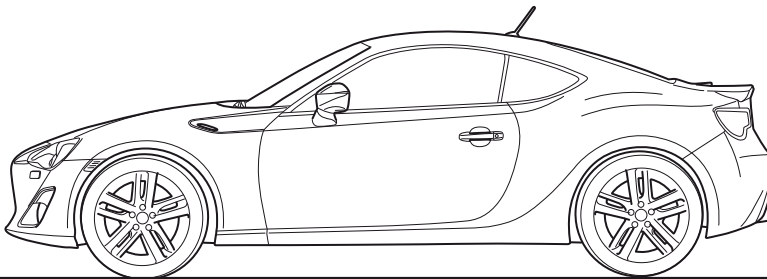
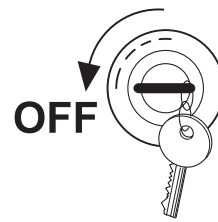
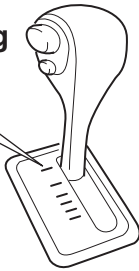

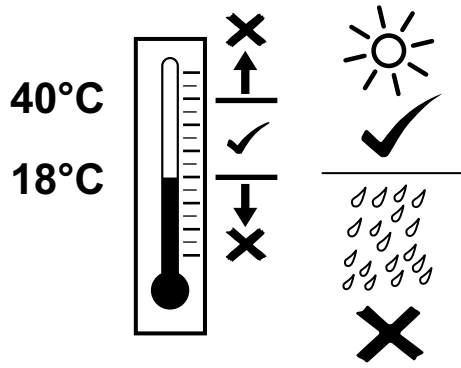

1

MS342-18001-A0
MS342-18001-C0

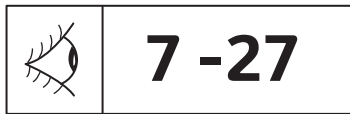

MS342-18002-00



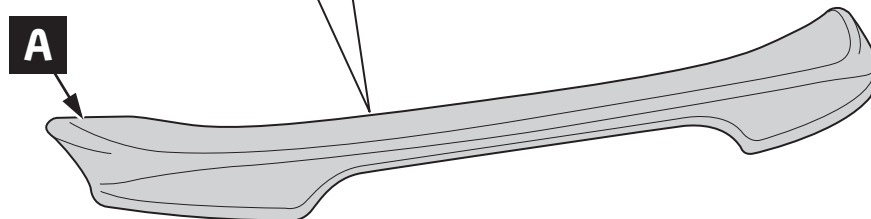
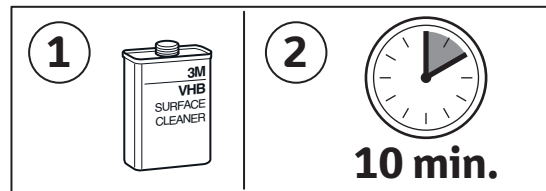

2

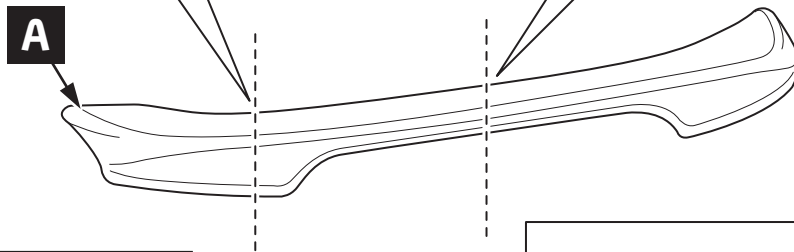
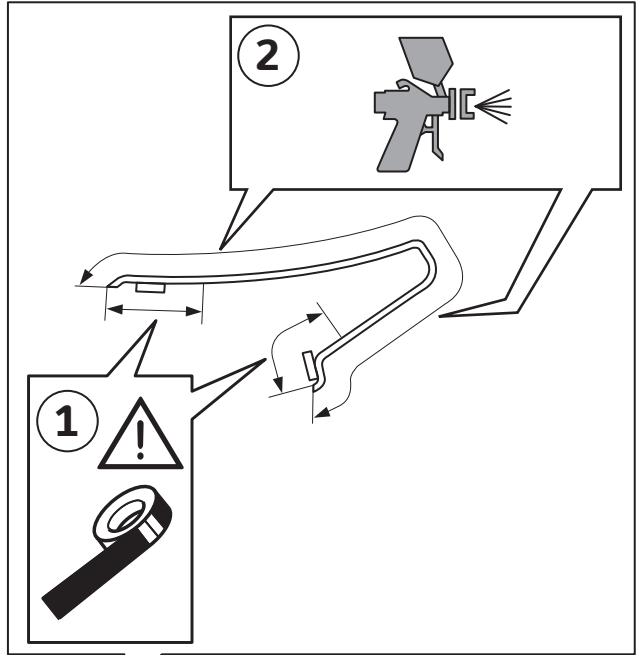
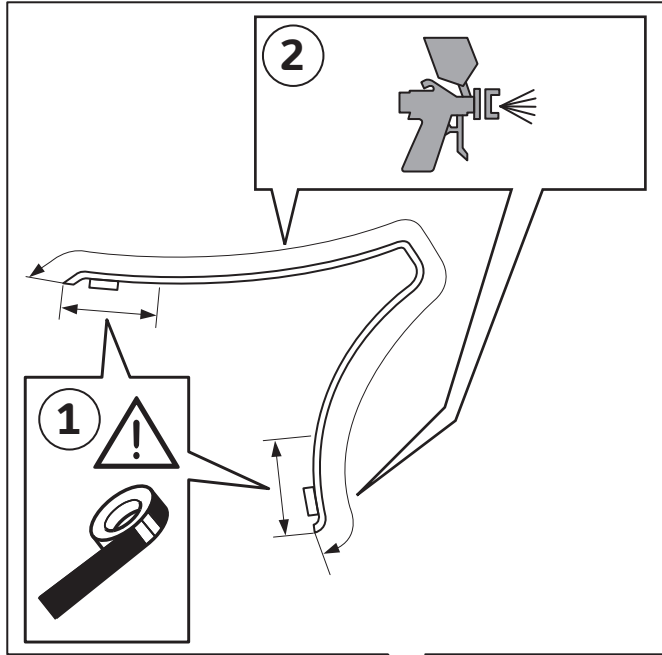

3



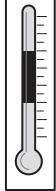

13 of 14
14 of 14



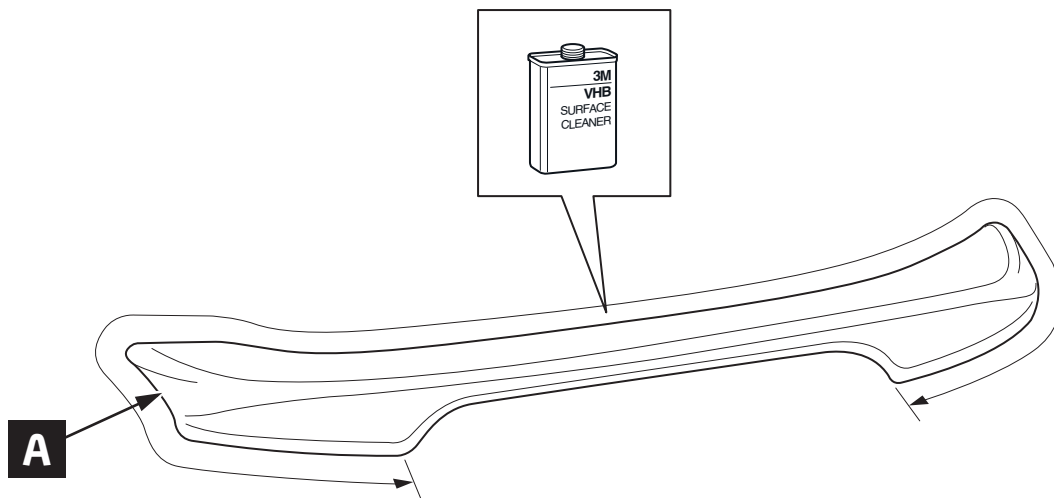

70°
>70°

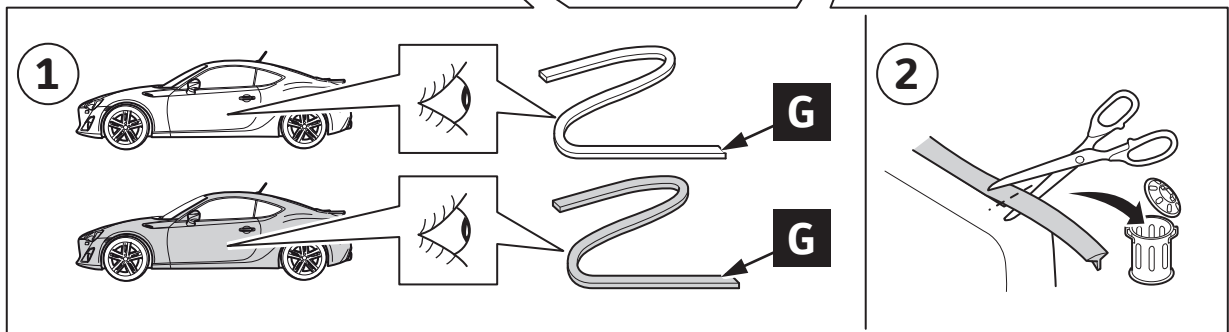
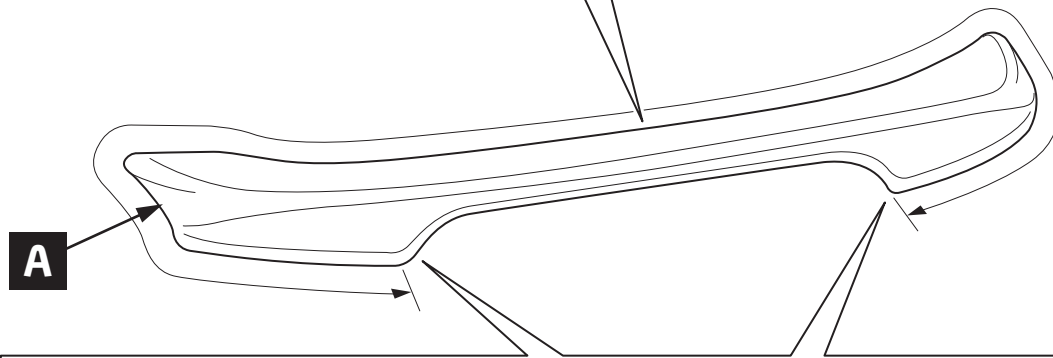
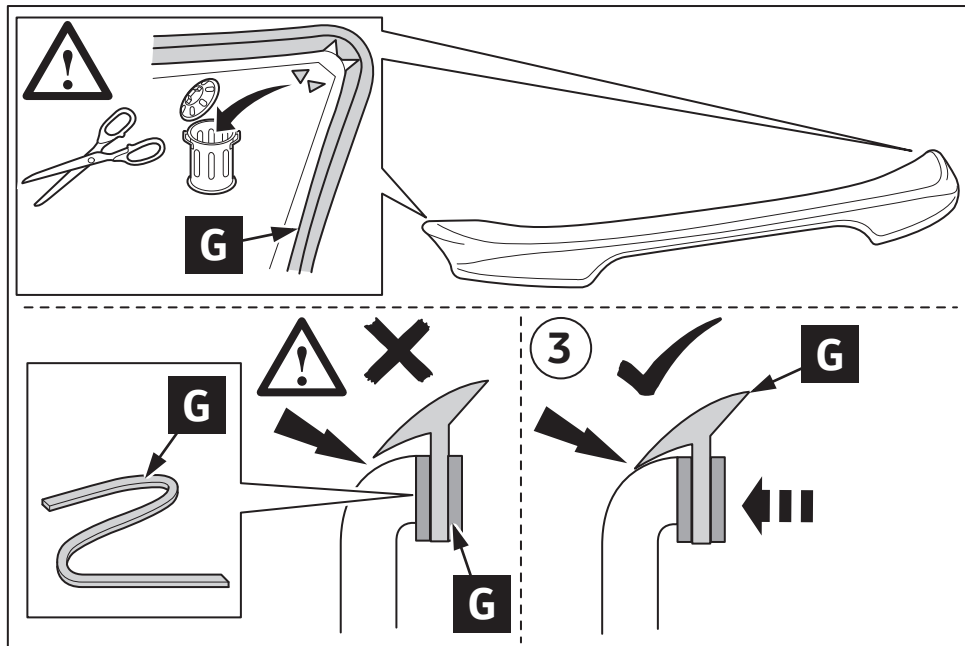
4

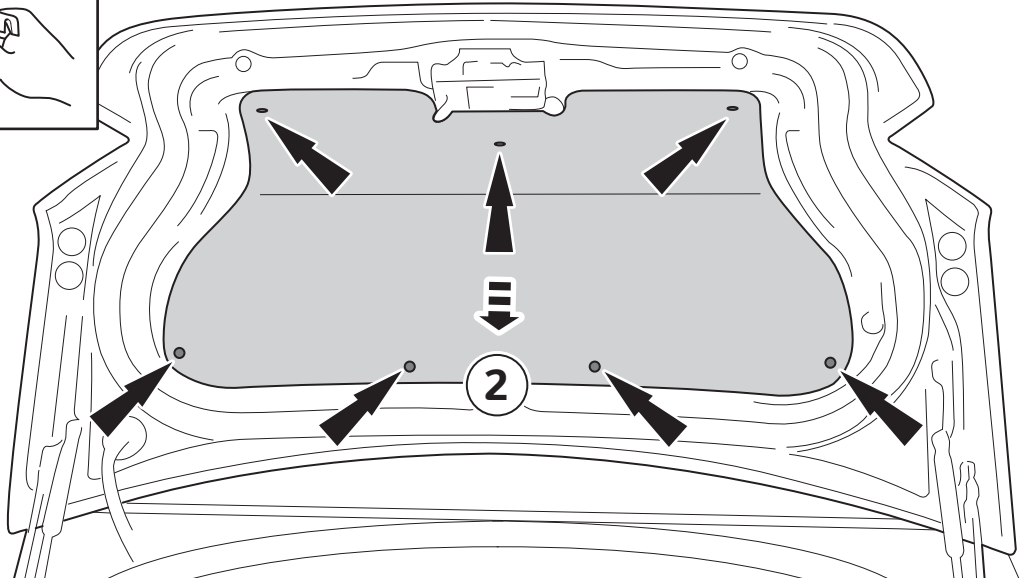
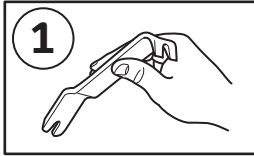

5





7

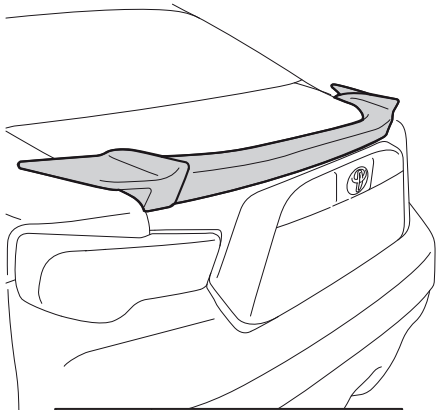

9-11

8

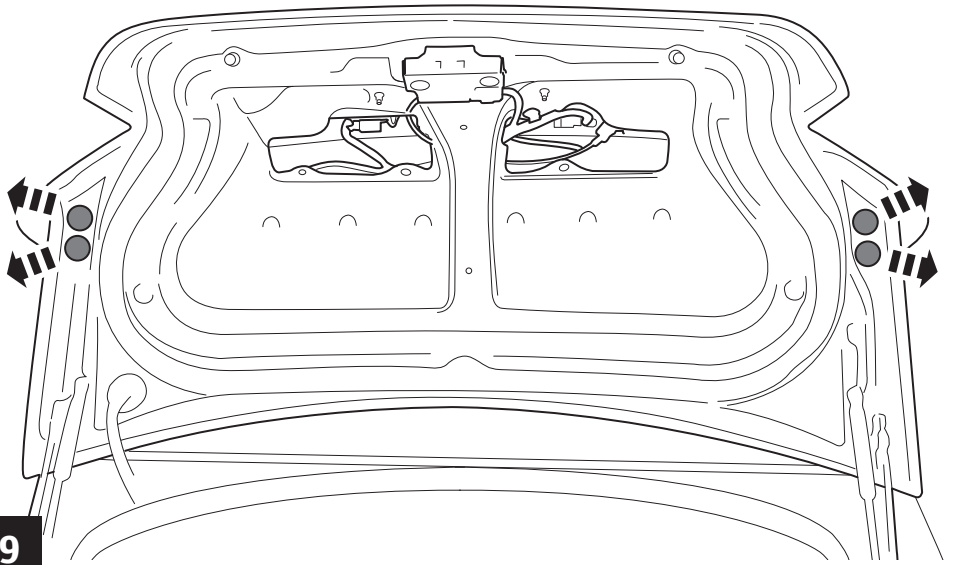

9

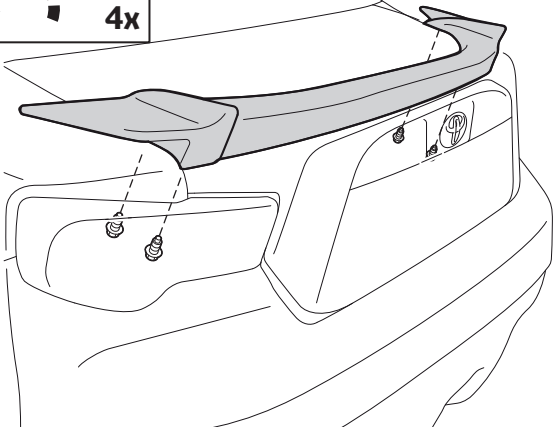
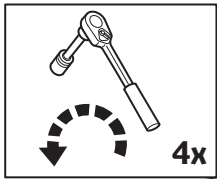

10

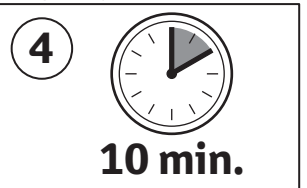
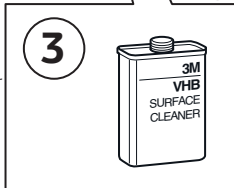
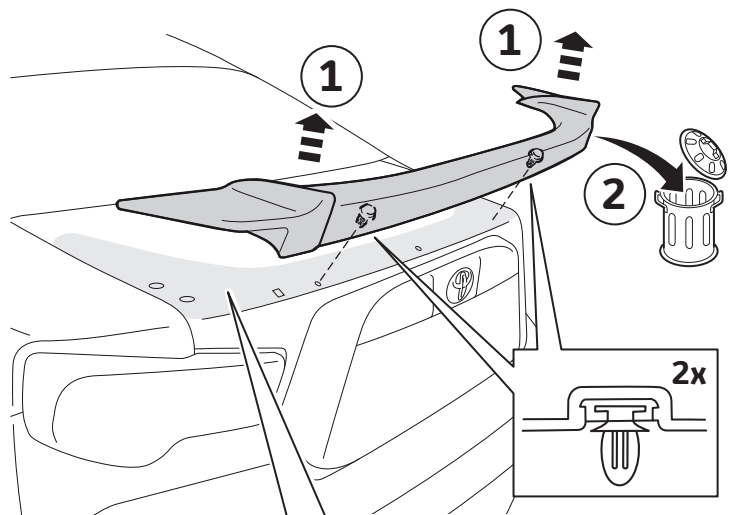

11

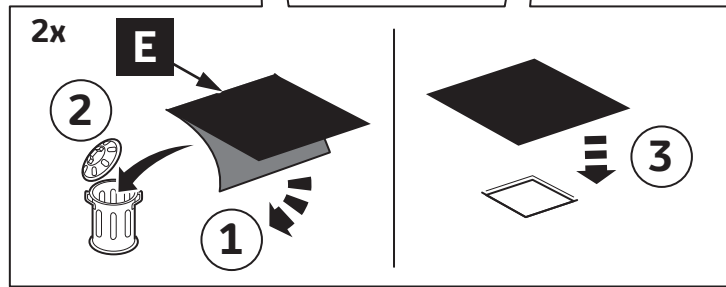
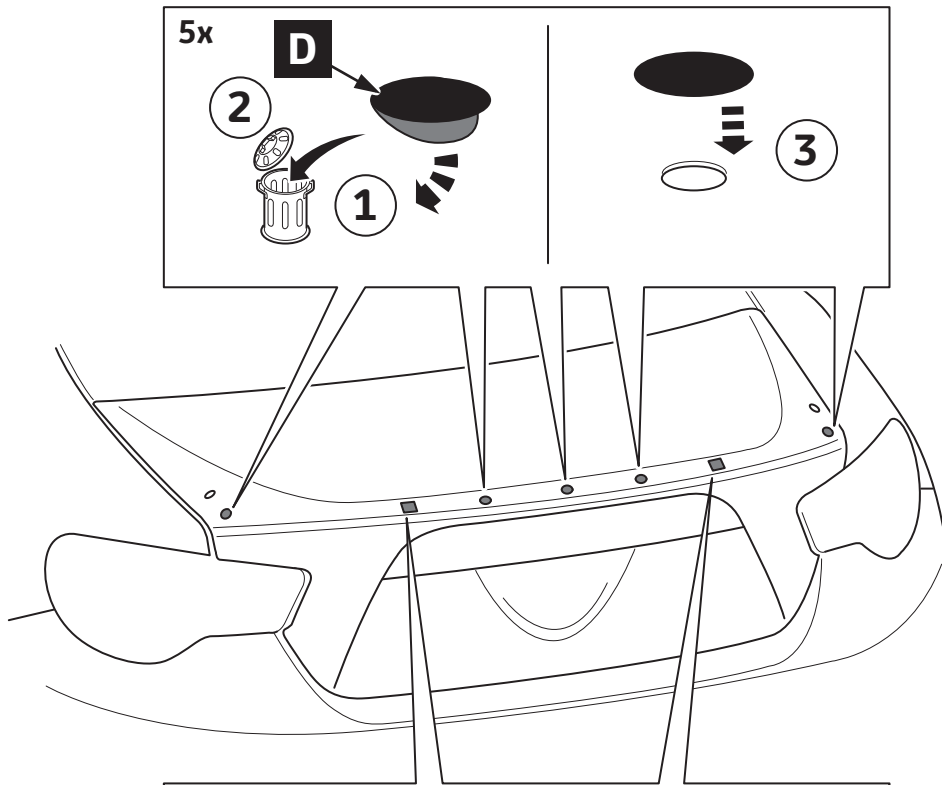

12

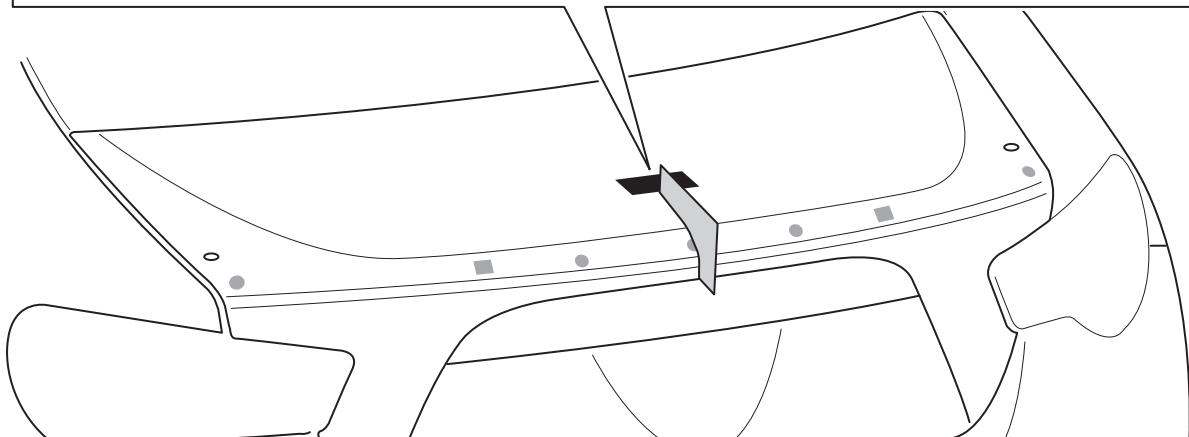
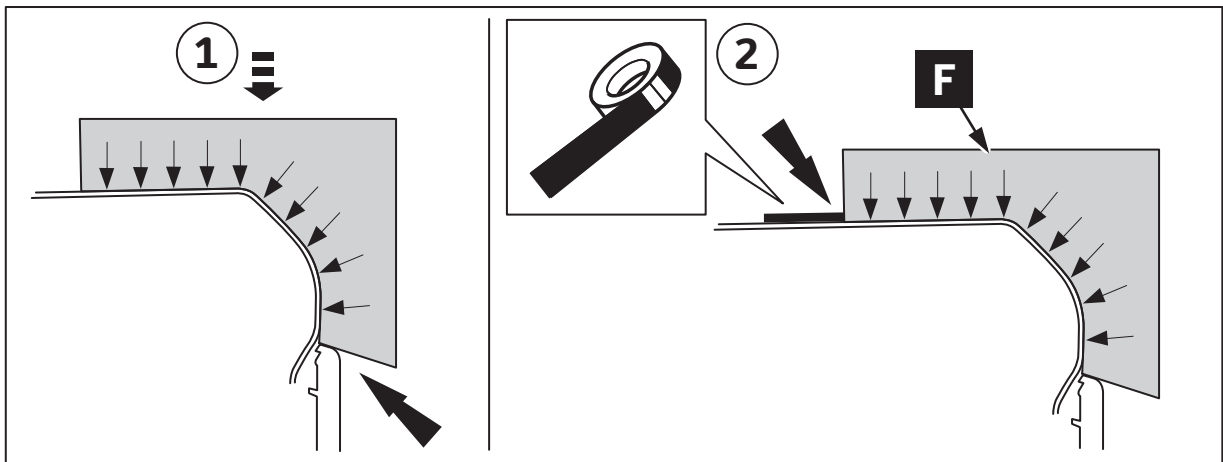

13

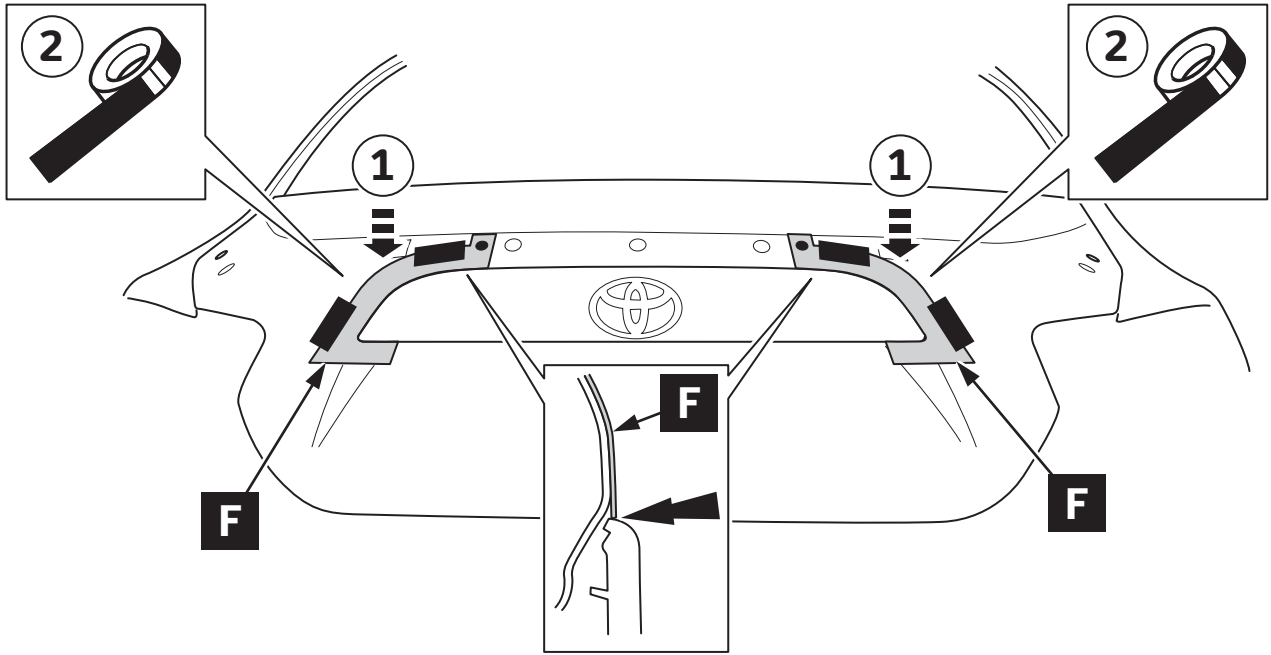

14

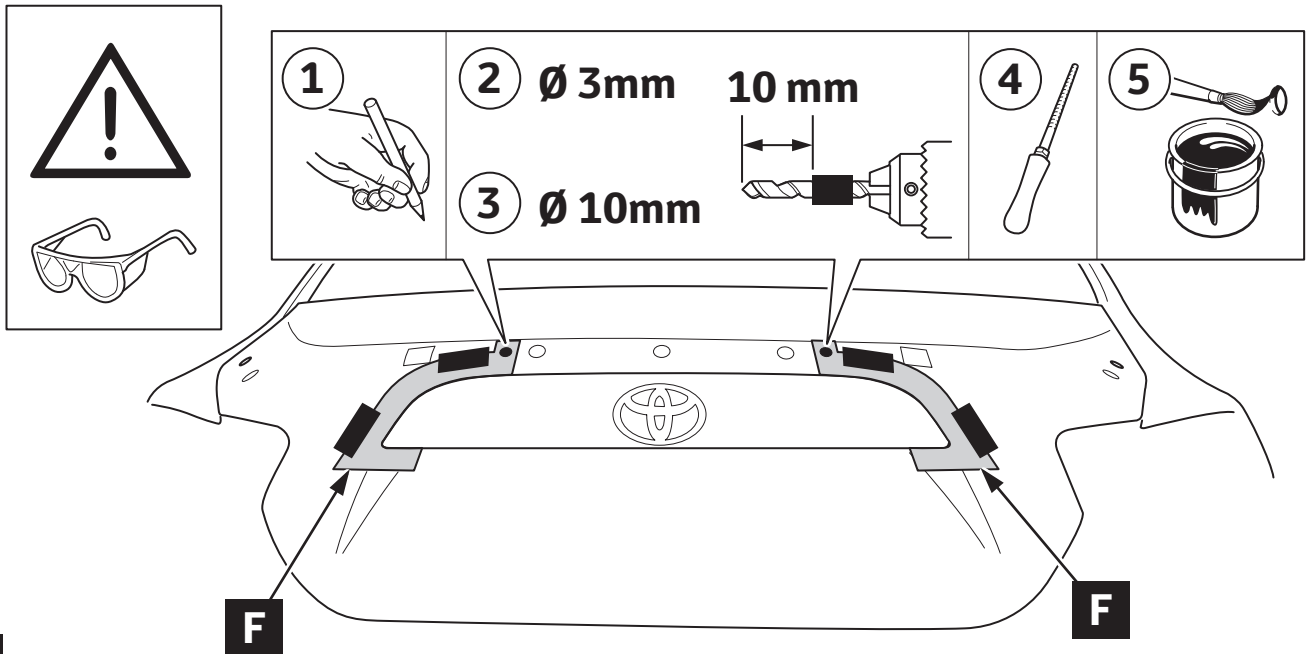

15

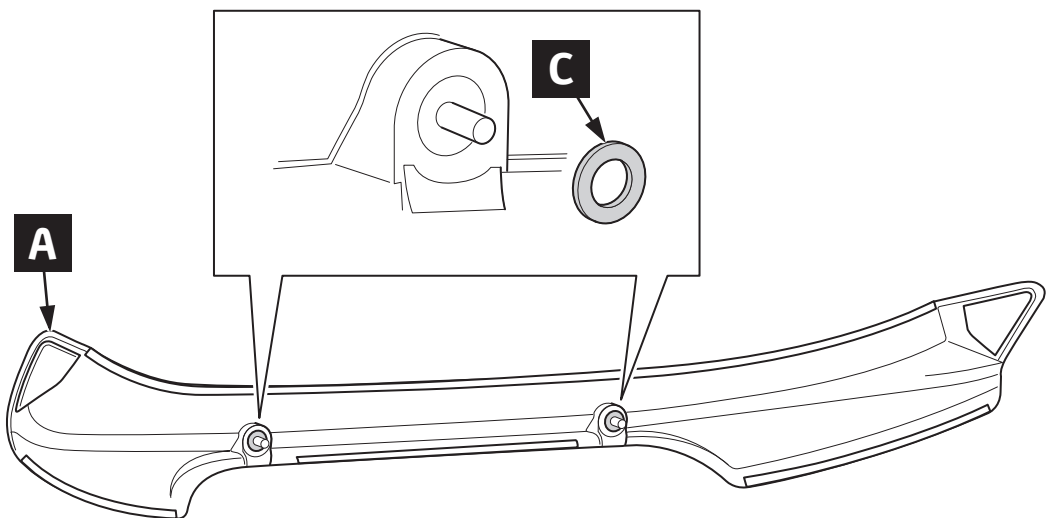

16

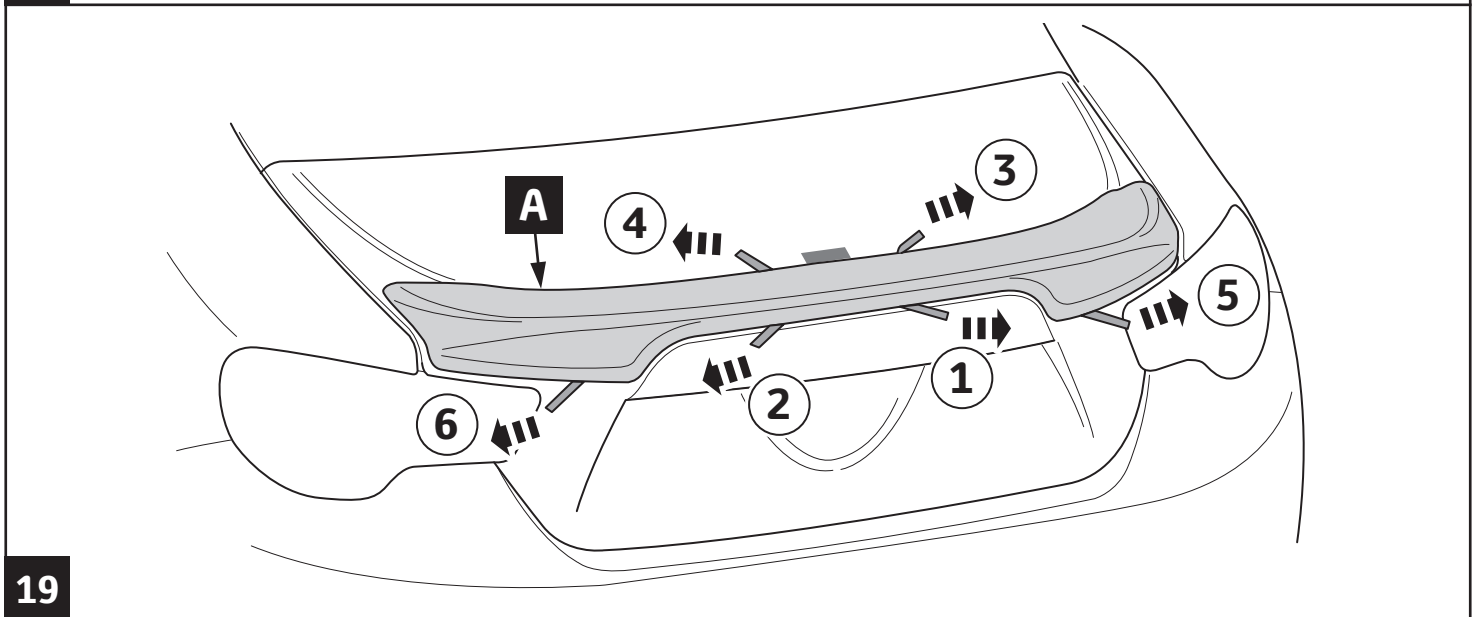
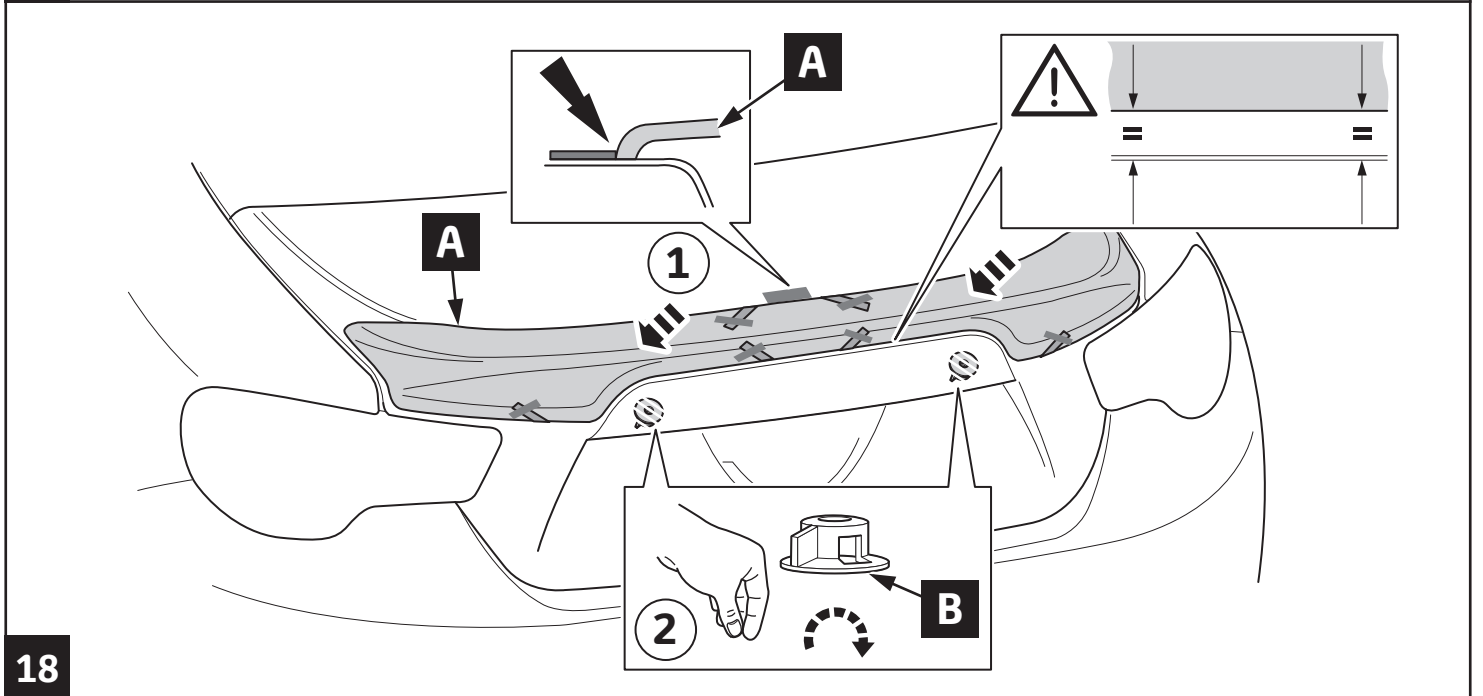
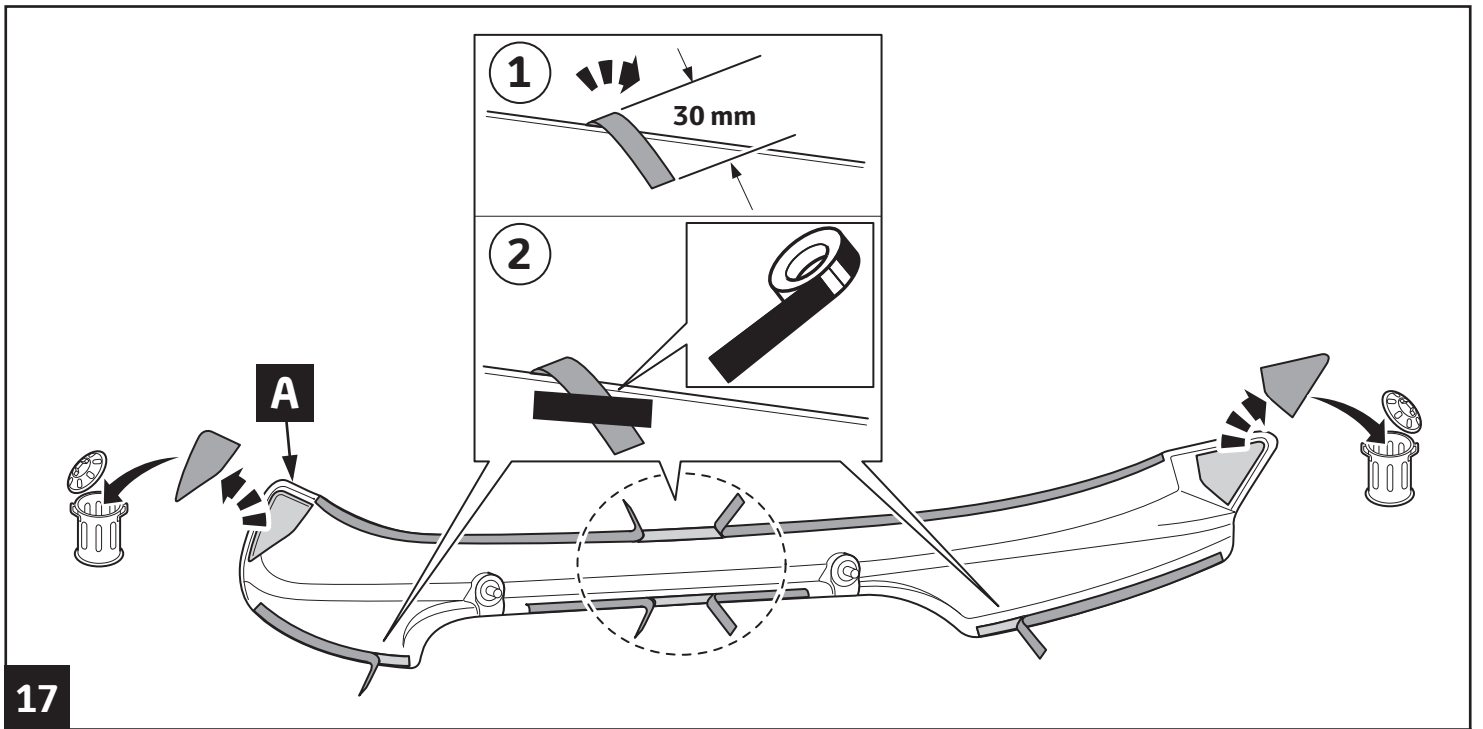

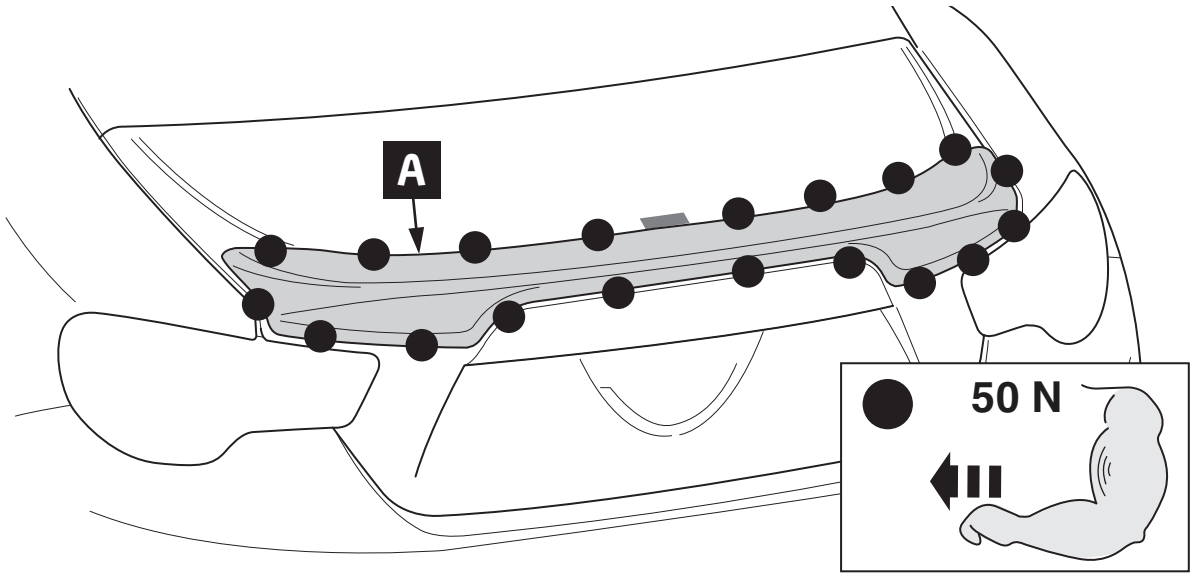

20

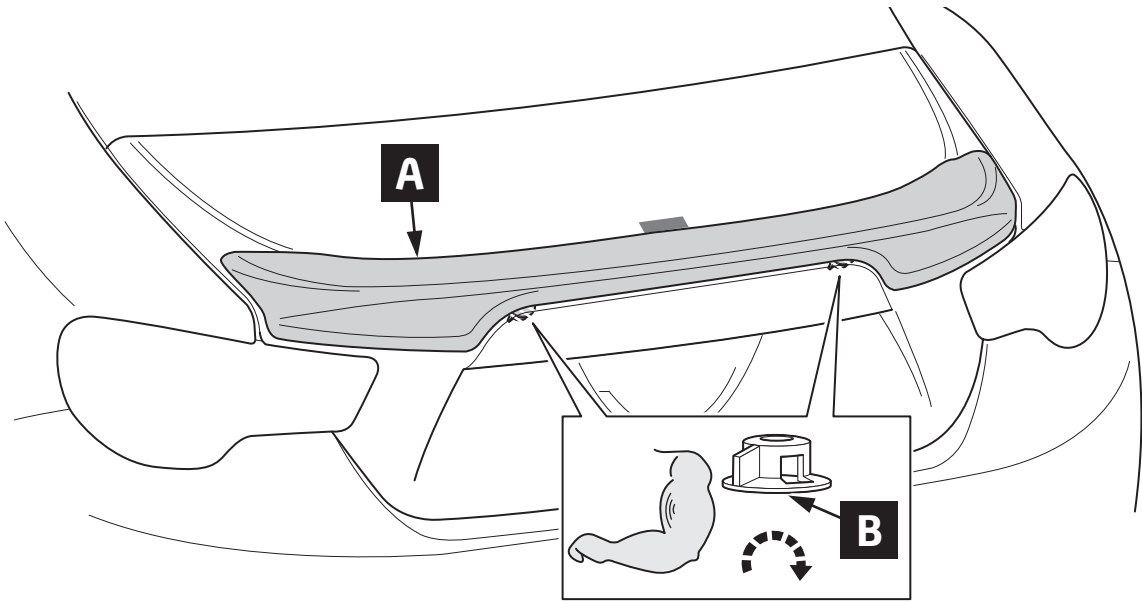

21



24 h



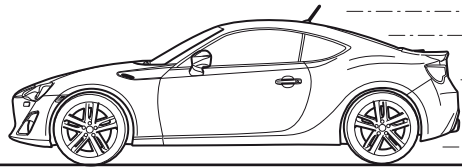



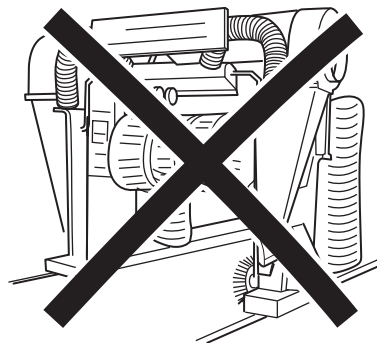













>100 km/h

















72 h



22

<p>GB</p> <p>Painting instructions for primed parts</p>	<p>800-1000</p>     	<p>Grind the primed component smoothly (P800-P1000). Avoid grinding through the primer.</p> <p>Check faulty spots, repair them and grind repaired places smoothly (P800-P1000). Re-prime ground-through spots using a suitable plastic primer.</p> <p>Thoroughly clean using a silicone remover.</p> <p>It is important to ensure adequate component support during the process of painting (distortion risk)! Paint buildup and application technique according to the paint manufacturer; the elasticity-impacting additives specified by the paint manufacturer are particularly important. The material designation is visible in the interior of the component (>.....<, z.B. >PUR-MF15<).</p> <p>No stoving of the paint (maximum 40°C)!</p>
<p>D</p> <p>Lackieranleitung für grundierete Teile</p>	<p>800-1000</p>     	<p>Grundiertes Bauteil anschleifen (P800-P1000). Durchschleifen der Grundierung vermeiden.</p> <p>Auf Fehlerstellen prüfen und ausbessern sowie Reparaturstellen anschleifen (P800-P1000). Durchschleifstellen mit geeigneter Kunststoffgrundierung nachgrundieren.</p> <p>Gründlich mit Silikonentferner reinigen.</p> <p>Auf ausreichende Bauteilunterstützung während des Lackierprozesses ist zu achten (Verzugsgefahr)! Lackaufbau und Applikationstechnik nach Lackhersteller, auf die vom Lackhersteller vorgegebenen Elastikzusätze ist besonders zu achten. Die Materialbezeichnung ist auf der Bauteilinnenseite (>.....<, z.B. >PUR-MF15<) ersichtlich.</p> <p>Kein Einbrennlackieren (max. 40°C)!</p>
<p>F</p> <p>Instruction de vernissage pour pièces apprêtées</p>	<p>800-1000</p>     	<p>Poncer le composant apprêté (P800-P1000). Eviter une usure de la couche d'apprêt.</p> <p>Contrôler les emplacements défectueux et retoucher, poncer les emplacements de réparation (P800-P1000). Retoucher les emplacements usés par le ponçage avec un apprêt acrylique approprié.</p> <p>Bien nettoyer avec un produit anti-silicones.</p> <p>Veiller à bien soutenir le composant pendant le laquage (risque de déformation)! Respecter les instructions du fabricant de laque pour la composition et l'application de celle-ci, y compris les additifs plastifiants prescrits. Le code de matériau figure sur le côté intérieur du composant (>.....<, p. ex. >PUR-MF15<).</p> <p>Pas de laquage avec cuisson (max. 40°C) !</p>
<p>I</p> <p>Introduzione verniciatura per parti impregnate</p>	<p>800-1000</p>     	<p>Rettificare l'elemento dotato di mano di fondo (P800-P1000). Evitare che la mano di fondo sia asportata.</p> <p>Controllare l'eventuale presenza di punti difettosi e riparare, rettificare i punti di riparazione (P800-P1000). Riapplicare un'adeguata mano di fondo in materiale sintetico sui punti in cui la mano di fondo è stata asportata.</p> <p>Pulire accuratamente con prodotto per eliminare il silicone.</p> <p>Occorre assicurare un sufficiente supporto dell'elemento durante il processo di verniciatura (pericolo di distorsione)! Struttura della vernice e tecnica di applicazione secondo il produttore della vernice, occorre osservare particolarmente gli additivi elastici prescritti dal produttore della vernice. La designazione del materiale è riportata sul lato interno dell'elemento (>.....<, p.es. >PUR-MF15<).</p> <p>Nessuna verniciatura a fuoco (max. 40°C)!</p>

<p>NL</p> <p>Lakinstructie voor onderdelen in grondverf</p>	<p>800-1000</p>     	<p>Gegroundverfd component licht schuren (P800-P1000). Doorschuren van de grondlaag vermijden.</p> <p>Op onvolkomenheden controleren en herstellen alsook de gerepareerde plekken licht schuren (P800-P1000). Doorgeschuurde plekken met een geschikte kunststofgrondlaag nagronden.</p> <p>Met siliconenverwijderaar grondig reinigen.</p> <p>Let tijdens het lakken op een toereikende ondersteuning van de componenten (ivm vervorming)! Lakproces en applicatietechniek volgens de voorschriften van de lakfabrikant. Bijzondere aandacht is vereist voor de voorgeschreven toevoegingen t.b.v. de elasticiteit De materiaalbenaming bevindt zich aan de binnenkant van de component (>.....<, b.v.. >PUR-MF15<)</p> <p>Niet moffellakken (max. 40°C)!</p>
<p>E</p> <p>Instrucciones de Pintura para piezas con la primera capa</p>	<p>800-1000</p>     	<p>Lijar ligeramente la pieza imprimada (P800-P1000). Al lijar, no atravesar la imprimación.</p> <p>Examinar con respecto a partes defectuosas y retocar, así como lijar ligeramente las partes a reparar (P800-P1000). Reimprimir las partes atravesadas con una imprimación sintética adecuada.</p> <p>Limpiar minuciosamente con quitasilicona.</p> <p>Tener cuidado de apoyar suficientemente la pieza durante el proceso de lacado (¡peligro de deformación!). Estructura de la laca y técnica de aplicación según el fabricante de lacas. Tener cuidado especial de los aditivos elásticos prescritos por el fabricante de lacas. La designación del material puede verse en la parte interior de la pieza (>.....<, p. ej. >PUR-MF15<).</p> <p>¡No lacado al fuego (max. 40°C)!</p>
<p>P</p> <p>Instruções de Pintura para peças com a primeira demão</p>	<p>800-1000</p>     	<p>Lixar o componente com primeira demão (P800-P1000). Evitar o lixamento completo da primeira demão.</p> <p>Verificar pontos de falha e retocar, assim como lixar os pontos de reparação (P800-P1000). Passar uma primeira demão nos pontos que foram lixados por completo com pintura de fundo de material plástico.</p> <p>Limpar a fundo com removedor de silicone.</p> <p>Prestar atenção para um suporte suficiente do componente durante o processo de pintura (perigo de estiramento)! Estruturação do verniz e técnica de aplicação conforme o fabricante do verniz, observar especialmente os aditivos elásticos prescritos pelo fabricante do verniz. Adesignação do material se encontra no lado interno do componente (>.....<, p.ex. >PUR-MF15<).</p> <p>Não é verniz que tenha de sofrer cozimento (máx. 40°C)!</p>