

# BRZ

## 2016 Quick Reference Guide



**SUBARU**

*Confidence in Motion*



**For detailed operating and safety information, please refer to your Owner's Manual.**

## BASIC OPERATION

### Lock/Unlock doors

#### Remote keyless entry system

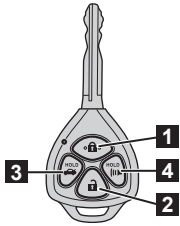

**Remote transmitter key (if equipped)**

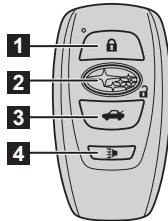

**Access key (if equipped)**

- 1** Locks both side doors
- 2** The driver's door will be unlocked. (To unlock other doors, briefly press the button a second time within 3 seconds.)
- 3** Unlocks the trunk lid (press and hold)
- 4** Sounds the alarm (press and hold)

#### Keyless access function (if equipped)

All doors and trunk will be locked/unlocked by the following procedures carrying the access key on your person. (The driver should always carry the access key.)

##### Side door:

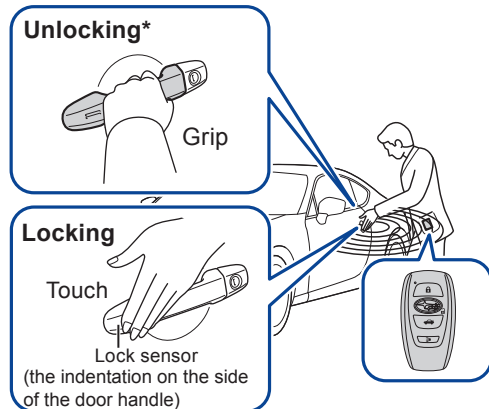

##### Unlocking the trunk lid:

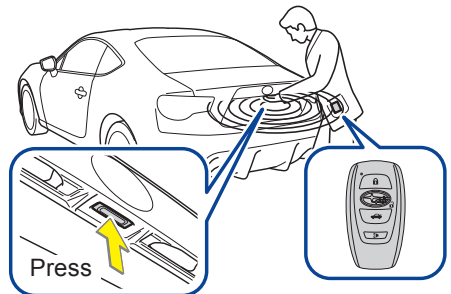

\*Grip the driver's door handle to unlock the driver's door. Grip the passenger's door handle to unlock all doors.

## Adjustable components

### Front seat

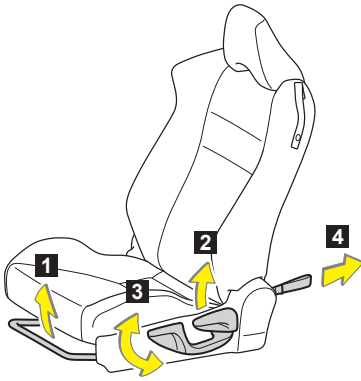

- 1 Seat position adjustment
- 2 Seatback angle adjustment
- 3 Vertical height adjustment (driver's side only)
- 4 Seatback fold strap

#### Getting in the rear seats:

Lift the seatback angle adjustment lever.

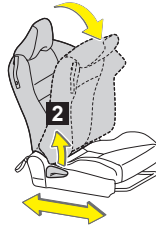

#### Getting out the rear seats:

Pull the seatback fold strap.

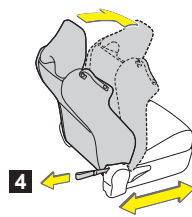

The seat can be slid forward and backward. (Front passenger seat only)

### Tilt/telescopic steering wheel

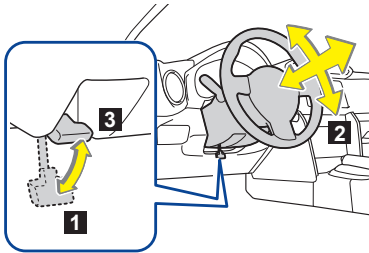

- 1 Hold the steering wheel and push the lever down.
- 2 Adjust to the ideal position by moving the steering wheel horizontally and vertically.
- 3 After adjustment, pull the lever up to secure the steering wheel.

### Outside rear view mirror switch

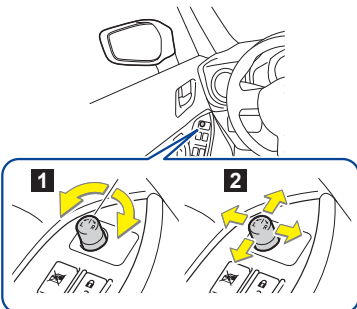

Ignition switch must be in **ACC** or **ON**.

- 1 Turn the control switch to the side that you want to adjust. **L** is for the left mirror, **R** is for the right mirror.
- 2 Move the control switch in the direction you want to adjust the mirror.

## Start/Stop engine

### Push-button ignition switch (if equipped)

Performing the following operations when carrying the access key on your person starts the engine or changes push-button ignition switch modes.

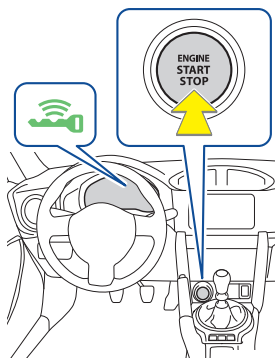

#### Starting the engine;

- 1: Check that the parking brake is set.
- 2: Check that the select lever is set in **P** (AT models).  
Check that the shift lever is set in neutral (MT models).
- 3: Firmly depress the brake pedal (AT models).  
Firmly depress the clutch pedal (MT models).  
The push button start system indicator light (green) will turn on.
- 4: Press the push-button ignition switch.

#### Stopping the engine;

- 1: Stop the vehicle (AT models). While depressing the clutch pedal, stop the vehicle (MT models).
- 2: Shift the select lever to **P** (AT models). Shift the shift lever to neutral (MT models).
- 3: Set the parking brake.
- 4: Release the brake pedal (AT models). Release the clutch pedal (MT models).
- 5: Press the push-button ignition switch.
- 6: Check that the keyless access with push button start system indicator light (green) is off.

### Changing push-button ignition switch mode

Modes can be changed by pressing the push-button ignition switch with the brake pedal (vehicles with an automatic transmission) or clutch pedal (vehicles with a manual transmission) released. (The mode changes each time the switch is pressed)

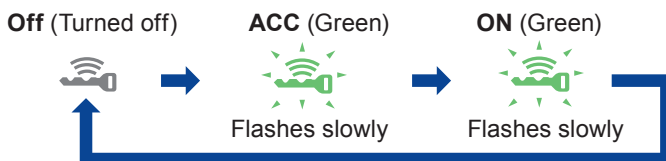

### Engine (ignition) switch (if equipped)

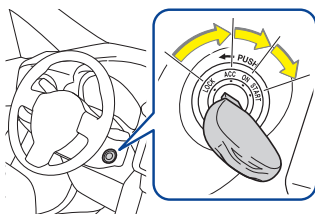

- LOCK** : The steering wheel is locked and the key can be removed. (Vehicles with an automatic transmission: The key can be removed only when the select lever is in **P**.)
- ACC** : Some electrical components such as the power outlet can be used.
- ON** : All electrical components can be used.
- START** : The engine can be started.

# Operate Select lever/Shift lever

## Automatic transmission (if equipped)

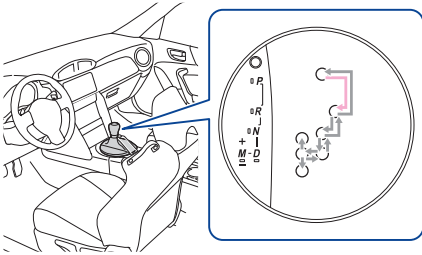

**P = Parking/Starting the engine**

**R = Reversing**

**N = Neutral**

**D = Drive**

For normal driving/Temporary manual mode driving

**M = Manual mode**

→ While the engine switch is in the **ON** position or the push-button ignition switch is in **ON** mode, move the select lever with the brake pedal depressed.

### Manual mode driving:

To enter manual mode, shift the select lever to the **M** position.

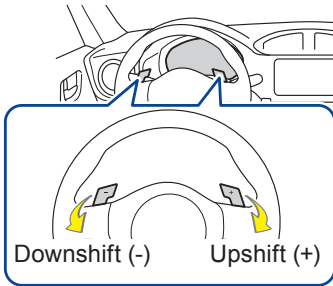

### Temporary manual mode driving (vehicles with paddle shift levers):

Temporary manual mode driving can be changed to by operating the paddle shift levers while the select lever is in the **D** position.

## Manual transmission (if equipped)

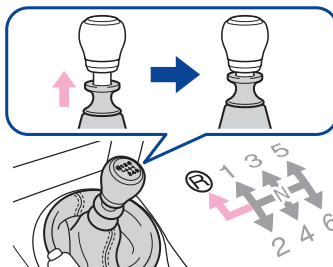

### Shifting the shift lever to R

Shift the shift lever to **R** while lifting up the ring section.

# DRIVER'S AREA

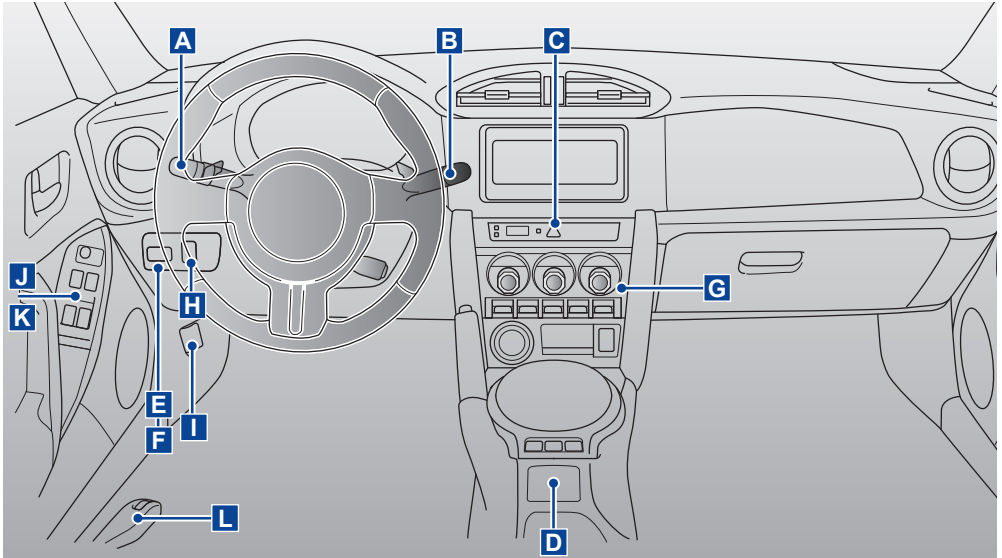

## A Headlight switch/Turn signal lever/Front fog light switch (if equipped)

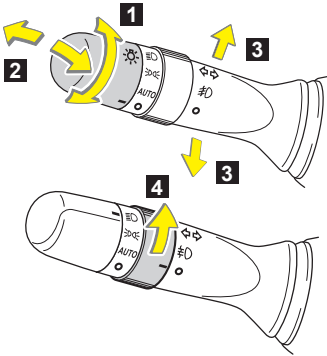

- 1** Headlights
- 2** High/low beam change, High beam flash
- 3** Turn signal
- 4** Front fog lights (if equipped)

## B Windshield wiper and washer switch

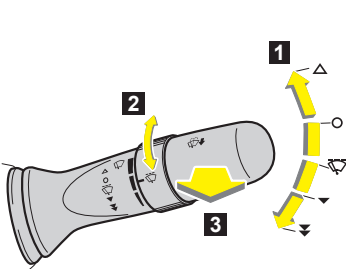

- 1** Wiper:  
To operate, push lever down/up to the following positions:  
  - △ : Temporary
  - : Off
  - ⏸ : Intermittent
  - ▼ : Low speed
  - ⚡ : High speed
- 2** Intermittent interval
- 3** Washer/wiper dual operation

## C Hazard warning flasher switch

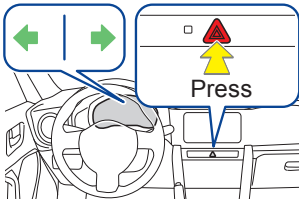

All the turn signal lights will flash.  
Use the switch to warn other drivers.

## D Seat heater switches (if equipped)

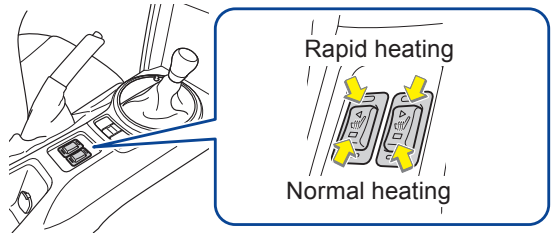

## E Instrument panel light control dial

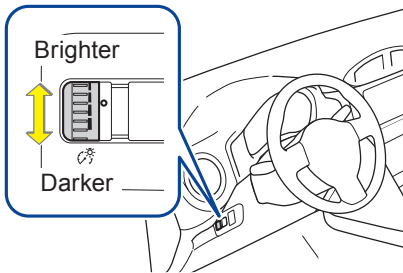

## F Manual headlight leveling dial

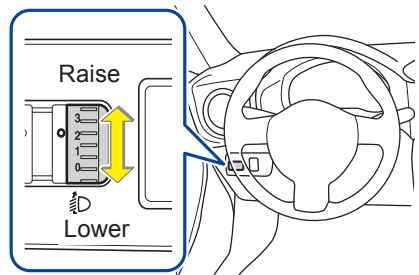

## G Windshield defogger/Rear window defogger switch

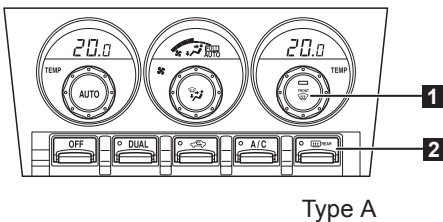

Type A

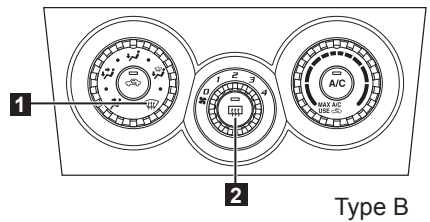

Type B

### 1 Windshield defogger switch:

The dehumidification function operates and fan speed increases.  
Set the outside/recirculated air mode button to outside air mode if the recirculated air mode is used. (It may switch automatically.)

### 2 Rear window defogger switch:

The rear window defogger and the outside rear view mirror defogger (if equipped) turns on. The function will automatically turn off after approximately 15 min.

## H Trunk lid opener switch

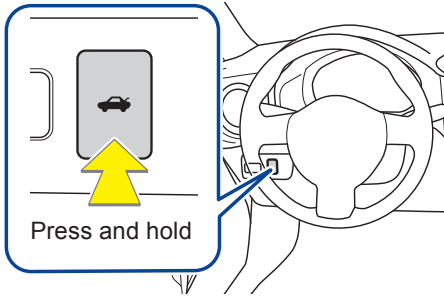

## I Engine hood lock release lever

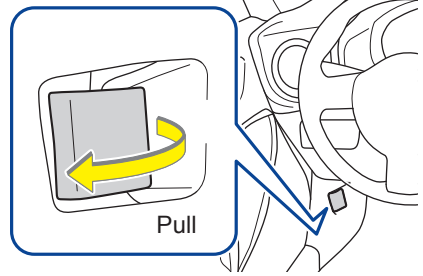

## J Power windows switches

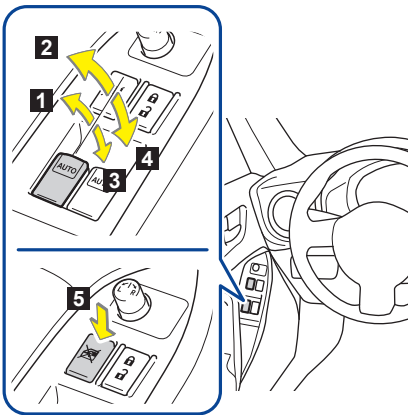

- 1 Closing
- 2 One-touch closing\*
- 3 Opening
- 4 One-touch opening\*

\* : Pushing the switch in the opposite direction will stop window travel partway.

- 5 Lock switch

## K Power door lock switch

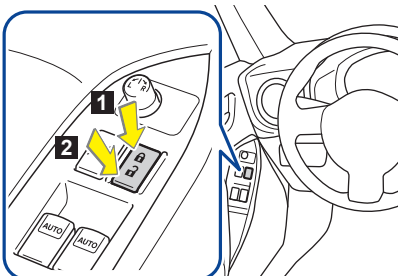

- 1 Locks both side doors
- 2 Unlocks both side doors



## L Fuel filler lid opener

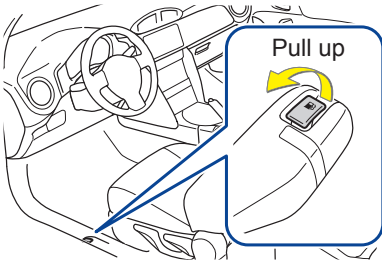

## Front seatbelt guide

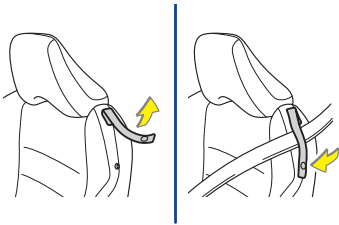

To enable the seatbelt to be easily extended, pass the seatbelt through the guide.

When getting in or out of the rear seats, release the seatbelt from the guide.

# VEHICLE PERFORMANCE FUNCTIONS

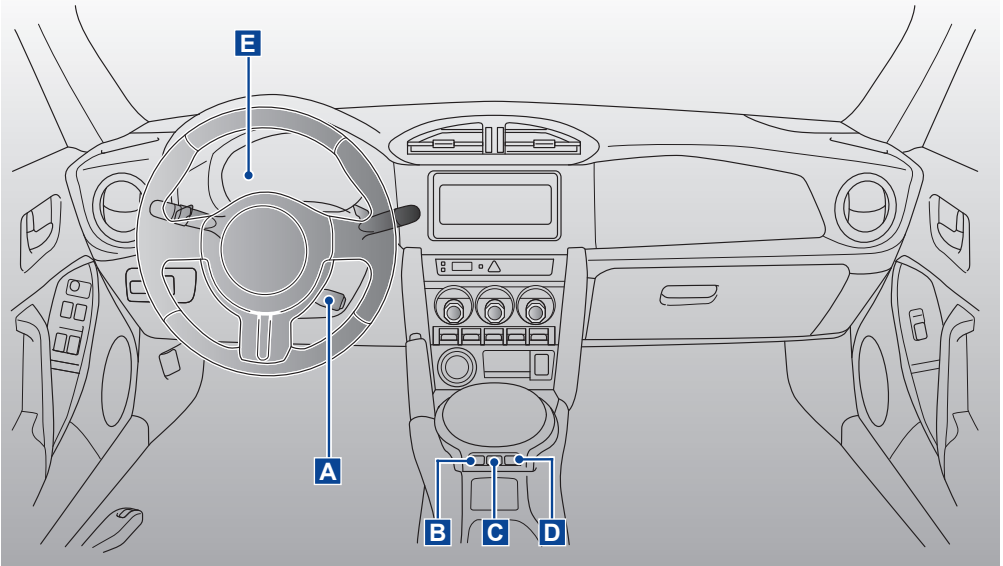

## A Cruise control switch

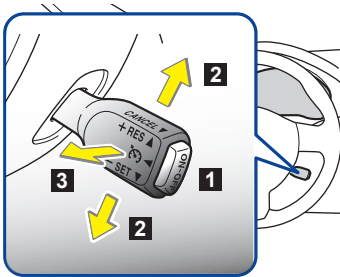

Use the cruise control to maintain a set speed without depressing the accelerator pedal.

- 1 ON-OFF button:** To activate and deactivate
- 2 +RES▲/-SET▼:**  
+RES▲ side: To increase the speed/To resume  
-SET▼ side : To set speed/To decrease the speed
- 3 CANCEL:** To cancel

## B Vehicle stability control (VSC)/TRAC off switch



### Turning off Traction Control System:

To turn the TRAC system off, quickly press and release the button. The Traction Control System OFF indicator light will come on. Press the button again to turn the system back on.

### Turning off both Traction Control System and Vehicle Stability Control (VSC) systems:

To turn the TRAC and Vehicle Stability Control (VSC) systems off, press and hold the **Vehicle stability control (VSC)/TRAC off** switch for more than 3 seconds while the vehicle is stopped. In this case, the brake LSD function remains on. Press the button again to turn the systems back on.



## C Driving pattern selector switch (if equipped)

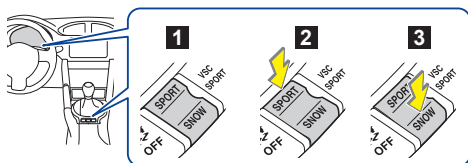

### Selecting a driving mode

By pressing the driving pattern selector switch, the following modes can be selected to suit driving and usage conditions:

#### 1 Normal mode

#### 2 Sport mode:

The **SPORT** indicator comes on. Use sport mode for sporty driving or when driving in mountainous regions with lots of curves.

#### 3 Snow mode:

The **SNOW** indicator comes on. Use snow mode for accelerating and driving on slippery road surfaces such as snow.

To cancel sport mode or snow mode, press the same side of the switch again.

## D VSC SPORT switch

Your vehicle is equipped with two types of control modes to accommodate various driving preferences. The control modes can be selected with the **VSC SPORT** switch.

Normal mode allows secure and smooth normal driving.



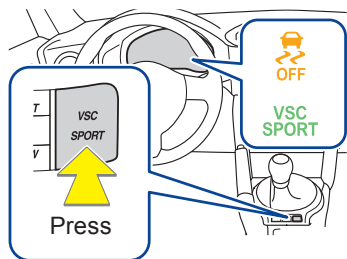

When the switch is pressed, Vehicle stability control (VSC) SPORT mode is activated.

Control characteristics such as the Vehicle stability control (VSC) and TRAC are adjusted to afford maneuverability closer to what a driver may have imagined, while a sense of security is retained.



Press the switch to activate the **VSC SPORT** mode. The **VSC SPORT** indicator and Vehicle stability control (VSC) off indicator come on when in Vehicle stability control (VSC) SPORT mode.

Modes can be selected to suit your driving conditions as follows:

Driving conditions	Indicator lights	Switch operation
Sport driving	 	The <b>VSC SPORT</b> switch is pressed.
	  	The <b>VSC SPORT</b> switch and the <b>Vehicle stability control (VSC)/ TRAC off</b> switch are quickly pressed and released.

## E Switch the display

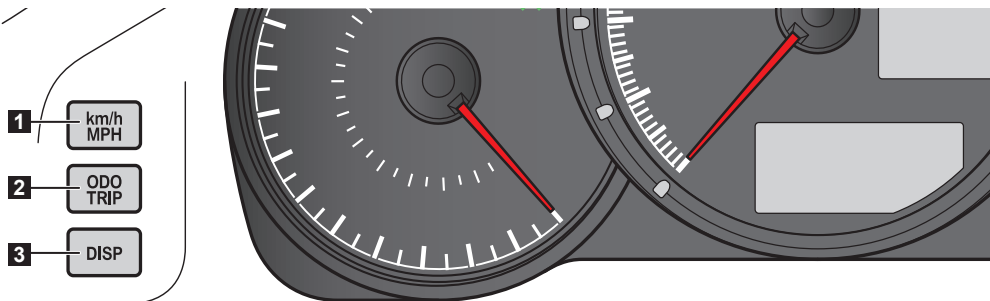

### 1 km/h MPH switch:

Each time the switch is pressed, the display inside the meter changes between km/h and MPH.

### 2 ODO TRIP switch:

Each time the switch is pressed, the display changes as follows.

Odometer



Trip meter A



Trip meter B



Setting screen for the shift position indicator and shift-up indicator (MT models).



Setting screen for tachometer indicator needle movement function when starting the vehicle.



### 3 DISP switch:

Each time the switch is pressed, the display changes as follows.

Outside temperature



Current fuel consumption



Setting screen for the REV indicator



Average fuel consumption



# MAIN WARNING AND INDICATOR LIGHTS

Some warning/indicator lights illuminate for a few seconds in order to check themselves when the ignition switch is turned ON.

## Warning lights

Refer to your Owner's Manual for countermeasures when each warning light comes on. If necessary, consult your authorized SUBARU dealer.

### Malfunction indicator



Indicates a malfunction in:

- The electronic engine control system;
- The electronic throttle control system;
- The electronic automatic transmission control system.

### Brake system warning



- Low brake fluid
- Malfunction in the brake system
- The parking brake is not released.

### Charging system warning



Indicates a malfunction in the vehicle's charging system.

### ABS warning



Indicates a malfunction in:

- The ABS;
- The brake assist system.

### Low engine oil pressure warning



Indicates that the engine oil pressure is too low.

### Electric power steering warning



Indicates a malfunction in the electric power steering system.

### SRS airbag system warning



Indicates a malfunction in:

- The SRS airbag system;
- The seatbelt pretensioner system;
- The front passenger occupant detection system.

### Automatic transmission fluid temperature warning (if equipped)



Indicates that the automatic transmission fluid temperature is too high.

### Driver's seatbelt reminder



Warns the driver to fasten his/her seatbelt.

### Front passenger's seatbelt reminder



Warns the front passenger to fasten his or her seatbelt.  
Location: On the center panel.

### Open door warning



Indicates that a door or the trunk lid is not fully closed.

### Low fuel level warning



Fuel level is low.

## Keyless access with push button start system indicator (if equipped)



**Flashing in YELLOW** : Indicates a malfunction in the keyless access with push button start system.

**Illumination in GREEN** : The keyless access with push button start system is activated.

Please see the Owner's Manual for details.

## Cruise Control indicator



**Illumination in YELLOW** : Indicates a malfunction in the cruise control system.

**Illumination in GREEN** : The cruise control system is activated.

Please see the Owner's Manual for details.

## Slip indicator



**Illumination** : Indicates a malfunction in the TRAC/Vehicle stability control (VSC) system.

**Flashing** : The TRAC/Vehicle stability control (VSC) system are operating.

## Indicator lights

The following indicators show the current status of your car. Refer to the Owner's Manual for more information.



**Turn signal indicator**



**Headlight high beam indicator**



**Front fog light indicator (if equipped)**



**Security indicator**



**Airbag on-off indicator**



**Vehicle stability control (VSC) off indicator**



**SPORT indicator (AT models)**



**SNOW indicator (AT models)**



**VSC SPORT indicator**



**SET indicator**



**REV indicator**



**Traction Control System OFF indicator**



**Upshift/downshift indicator (AT models)**



**Shift position and shift range indicator (AT models)**



**Shift position indicator (MT models)**



**Shift-up indicator (MT models)**

subaru.ca

All illustrations, specifications, features and photographs contained in this brochure are based on product information available at the time of its printing, and may not be completely accurate following its publication. Colours shown may vary due to reproduction variations in the printing process, and some vehicle parts cannot be shown in certain photographs. Subaru Canada, Inc. reserves the right to discontinue or make changes at any time, without notice or incurring obligations, to colours, materials, equipment, accessories, features, specifications and models, or to change their prices. Please visit our Web site for the latest information and specifications. For detailed operating and safety information, please consult your Owner's Manual. For complete details on product updates, warranties or the Subaru C.A.R.E. program, please contact your Subaru dealer. BRZ and Subaru are registered trademarks. Printed in Canada. © 2015 Subaru Canada, Inc. 2016 model year.



**Environmental Management System (EMS)**  
**ISO 14001:2004 certified by SGS**  
[www.subaru-earth.com](http://www.subaru-earth.com)

SUBARU CANADA, INC. / FUJI HEAVY INDUSTRIES LTD.